

Original Article**Instrumentation for Six Electrode Focused Impedance Method (FIM-6) for the study of localized regions in a volume conductor**Trilochan Khanal¹, K Siddique-e Rabbani²

1: Department of Physics, Tribhuvan University, Nepal

2: Department of Biomedical Physics & Technology, University of Dhaka, Bangladesh

Email: khanaltrilochan@gmail.com, rabbani@du.ac.bd**Abstract**

Focused Impedance Method (FIM) is a new and simple technique of electrical bio-impedance that provides an opportunity for localized measurement down to reasonable depths of the body surface using skin surface electrodes. Conceived by one of the authors (KSR) and developed in Bangladesh by a group led by him, FIM has potential applications in physiological study and in the detection or diagnosis of diseases and disorders. Being a simple technique, it is particularly suitable for low and medium income countries (LMIC). To obtain long term benefit from any technology it is necessary that the technology is understood and developed indigenously, particularly under the limitation of a resource limited country. Indigenous development also allows for further improvisation, innovation, and application in future. This paper presents the indigenous design and development of the electronic instrumentation necessary for the implementation of six electrode version of Focused Impedance Method (FIM-6) in Nepal. The work involved basic characterization of the necessary circuit blocks developed through experimental validation. In particular, the design of isolating ferrite transformers required for the instrumentation posed a challenge which was solved limiting the range of the instrumentation to range variations encountered in practice on the human body, for which initial experiments were carried out on a live human subject. This led to a simplified design. The values obtained using the developed circuitry appears to give reasonable accuracy and would be useful for further implementation of the instrumentation using PCBs. However, further work can also be taken to improve the design of the current source used and of the transformers. Thus this work satisfies the initial requirement of attempting indigenous development of the FIM technique in an LMIC like Nepal.

Keywords: *FIM, Focused Impedance, Bio-impedance, Indigenous technology, Current transformer*

1. INTRODUCTION

Measurement of electrical impedance of tissue using skin surface electrodes to assess physiological information of a biological body has been the subject of interest for many years. The Focused Impedance Method (FIM) is a new technique developed in the Biomedical physics

laboratory of the University of Dhaka [1-3]. It has three basic versions using 8 electrodes, 6 electrodes and 4 electrodes respectively. The 6-electrode FIM configuration (FIM-6) is shown in Figure 1 for a two dimensional conductor, where electrodes are indicated by small white circles. Here an alternating current I_1 is driven between two electrodes, arranged vertically. A second alternating current I_2 is driven between two electrodes, arranged horizontally. Two potential measuring electrodes are positioned at intermediate diagonal positions. It may be seen that these two electrodes lie at the intersection points of respective equipotential lines due to the two orthogonal pairs of currents. For current I_1 , the potential V_1 across these potential electrodes basically gives the potential difference between the two equipotential lines as shown by the edges of the horizontally shaded region. The resulting transfer impedance, given by V_1/I_1 essentially gives the Transfer Impedance Z_1 of this horizontal shaded region, though the contribution of different points within this region will vary.

Similarly, for current I_2 , the potential V_2 across these potential electrodes basically gives the potential difference between the two equipotential lines as shown by the edges of the vertically shaded region. The resulting transfer impedance, given by V_2/I_2 essentially gives the Transfer Impedance Z_2 of this vertical shaded region, though the contribution of different points within this region will vary.

Now if the two currents (I_1 and I_2) are electrically isolated, have the same magnitude and frequency, and have the same phase (coherent), then the measured potential will essentially give a summation of the two transfer impedances $Z_1 + Z_2$, which will have enhanced contribution from the dark shaded region in the centre. The average of the above sum has been termed the 'Focused Impedance', which is the basis of the 6-electrode FIM. Sometimes, the sum is also referred to as the Focused Impedance.

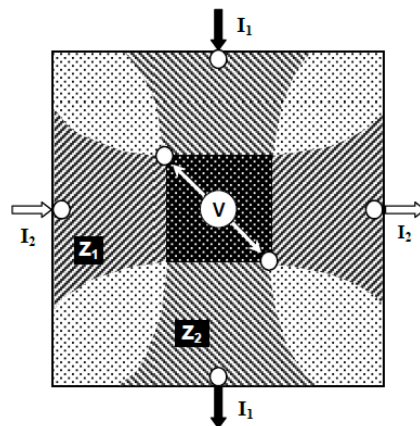

Figure 1. Basic concept of FIM-6 [1]

FIM has many potential medical applications like lungs ventilation study, gastric emptying study, determination of abdominal fat thickness, Diagnosis of cancer etc. [4].

The present work was taken up to develop the necessary instrumentation for the FIM-6 technique in Nepal using locally available off-the-shelf electronic components (as much as possible). This was also aimed at emphasising the innovation of indigenous low-cost technology in developing countries like Nepal. The specific focus of the present work was to design the circuit for FIM-6 for localized lungs study in the human body. This involves the placement of six electrodes aimed at the study of desired lung region [5]. FIM has the potential to benefit the people who are deprived of modern health care technology as the technique is non-invasive and of low cost. The basic circuitry is similar to that developed by Rabbani et al [1] in Bangladesh but the conditions prevailing in Nepal was given preference. This paper presents the instrumentation design and measurement taken to evaluate its performance for different design parameters, which will enable a choice of suitable design for future study on human body.

2. METHODS

2.1 Instrumentation

2.1.1 Basic Instrumentation design

Figure 2 shows the block diagram for the instrumentation of six-electrode FIM configuration as developed by Rabbani et al [1], which was also followed in the present work, but with modifications in the detailed circuit design in the context of availability of components in Nepal.

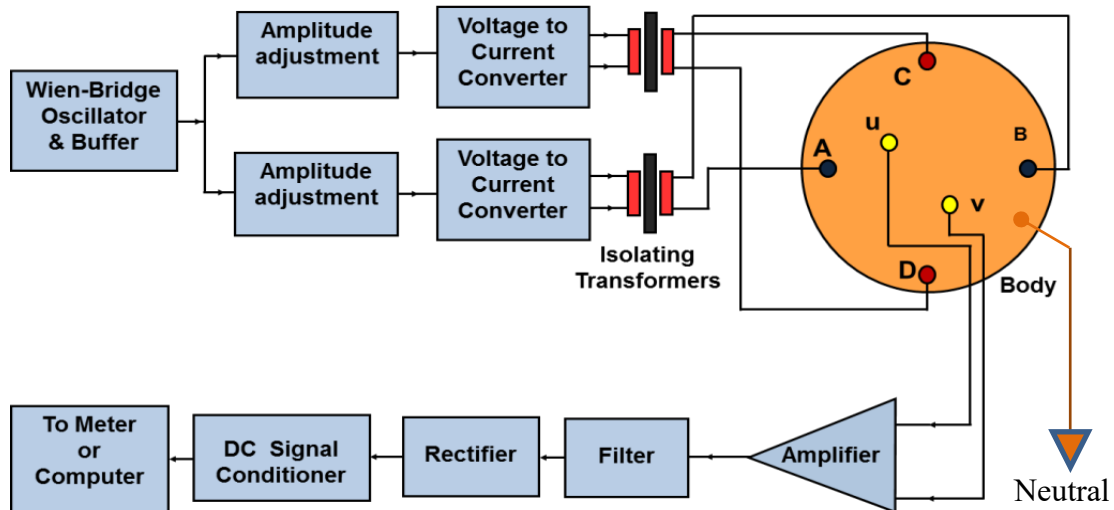

Figure 2. Block diagram for FIM-6 instrumentation [1,4]

In this basic design, output from a single Wien bridge oscillator with an oscillation frequency of about 10 KHz is used to drive two separate voltage-to-current converters, the outputs of which are then electrically isolated using two separate current transformers as shown in the figure. The two outputs from the transformers in turn drive two sets of orthogonal current electrode pairs (AB and CD) of the FIM-6 system. Since the transformers may have slight differences, the amplitude of the two current values is made the same using individual voltage adjustment circuitry placed before the individual voltage to current converters. Thus the two orthogonal currents have constant amplitude but are electrically isolated and are coherent, i.e. they have a constant phase relationship. Through appropriate choice of the polarity of the transformer terminals the phase of the two current waveforms are chosen so that the potentials appearing at the two potential electrodes are in phase. Therefore, a single potential measurement between the electrodes u and v gives a sum of the two orthogonal transfer impedance i.e. twice the focused impedance [3]. This single potential output is amplified, filtered, and converted to dc through active rectification. This dc signal is then conditioned and either read off in a voltmeter or acquired in a computer for further processing and display.

The current drive circuitry as shown in Figure 3 was designed and developed in the present work to generate an electrical signal with a specific amplitude with varying load impedance within a specific range. For the circuit design resistors, capacitors and ICS (TL071, TL072) as available locally in Nepal were used. The circuitry involved in the design of current drive section was first designed in electronic software (Proteus) and simulated. The circuit was then fabricated on a prototyping breadboard and evaluated.

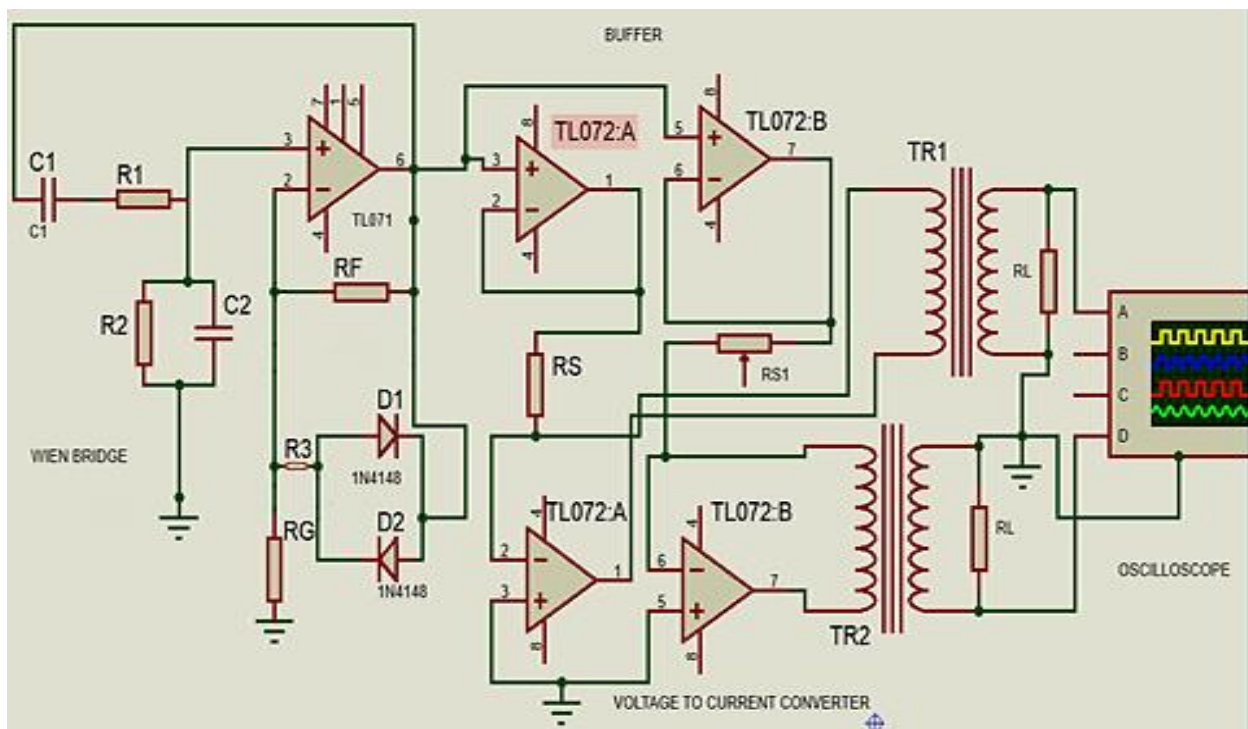

Figure 3. Circuit for current drive section for FIM-6 system designed in Proteus software

In the design, the amplitude output from Wien bridge oscillator at the frequency of 10KHZ was adjusted using diode clamping amplitude adjustment method using two 1N4148 signal diodes (D_1 and D_2) in series with a resistor R3. Typically R_F is set to a slightly greater value than 2 times R_G . The diodes and R3 automatically adjusts the amplitude to a certain value, which may be varied using R3. The same output was then injected to two V-I converters with floating loads in two branches, the outputs of which were isolated using two ferrite transformers, TR1 and TR2, with appropriate turns ratio. The current across the secondary of both the transformers when applied to load resistors within a specified range were expected to be constant.

Figure 4 shows a photograph of prototype of the fabricated circuitry. It was powered by a regulated dual power supply of +6 and -6 volts.

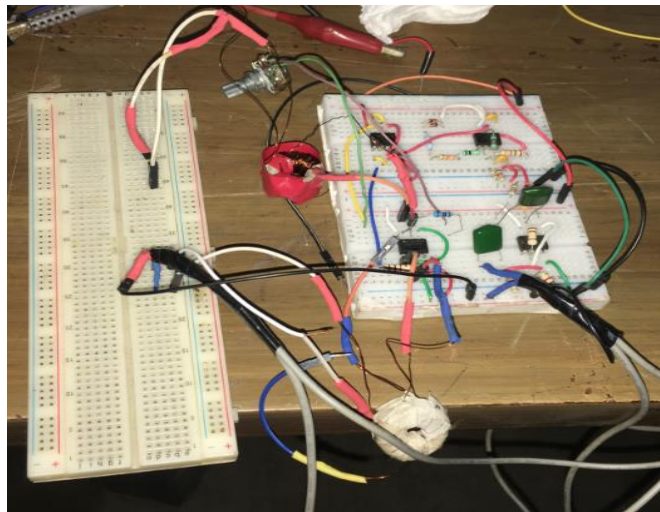

Figure 4. Prototype of the fabricated current drive circuitry for FIM-6 system

2.1.2 Design of isolating transformers

It was necessary to isolate the output of two current drives as shown in Figure 3 using transformers. It was a challenge to design the two isolating transformers at 10 KHz since the normal steel laminated core, used in general power line frequency transformers, could not be used. So ferrite cores had to be used which are suitable for high frequency applications [6]. Enameled copper wire of size 30 gauge was wound over the core, both for the primary and the secondary coils. The number of turns were adjusted so as not to saturate the core at the current being used. Different turn ratios for the transformer were experimented with so as to obtain a constant current over a reasonable range of load resistors across the secondary of the transformers.

2.1.3 Estimation of required load impedance range from real life experiments

To assess the range of load resistances actually encountered in the body, the circuit schematic shown in Figure 5 was used. This is in fact one channel of the FIM circuit shown in Figure 3. Here

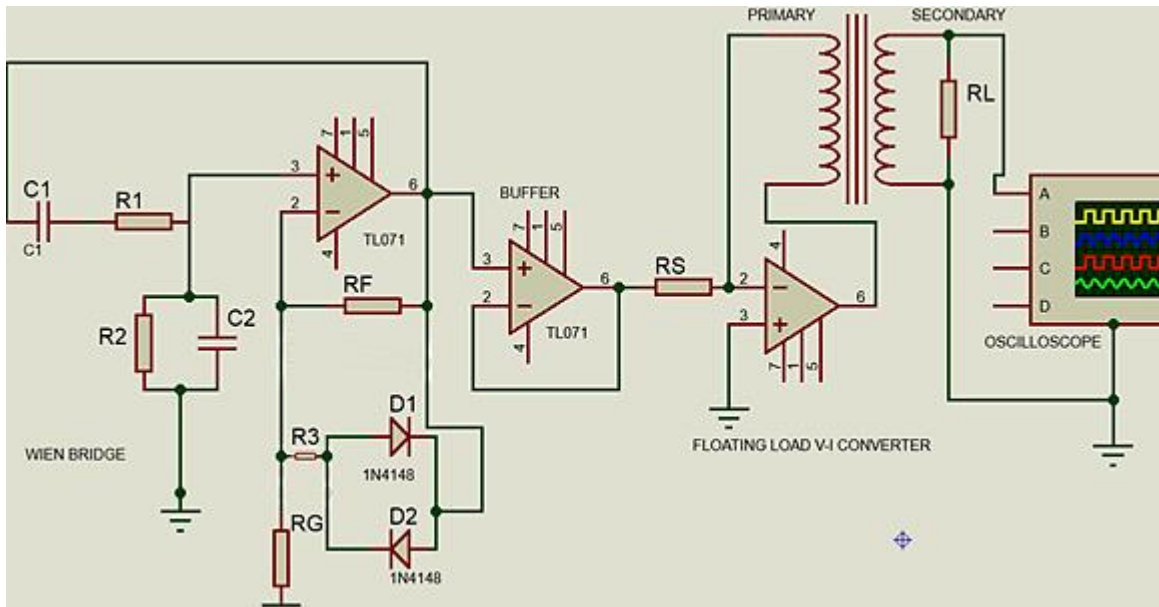

Figure 5. Single current drive channel of the circuit shown in Figure 3, used for measurements on human body and for evaluation of the performance of the circuit as an isolated constant current source.

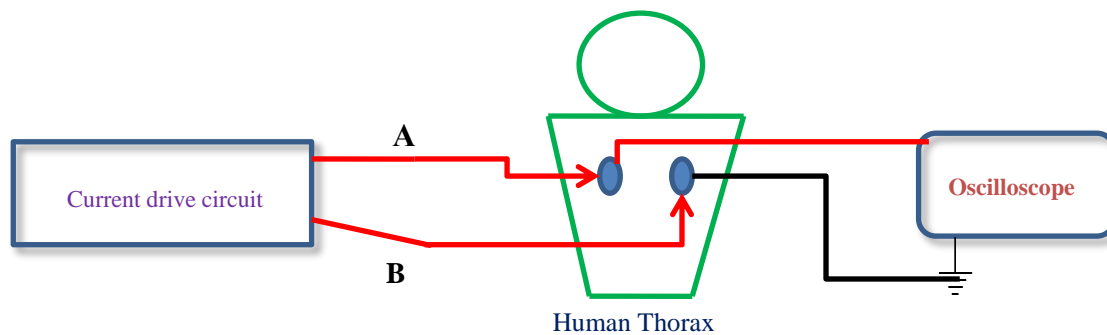

Figure 6. Block diagram of circuit arrangement for estimating body impedance

R_S is the series resistance of the voltage to current converter circuit which plays an important role in specifying the constant current as the current flowing through R_S equals the current flowing through the primary coil of the isolation transformer. The secondary coil of the transformer provides an isolated current drive to the load resistance R_L shown, which in this case would be the impedance offered by the human body through two electrodes connected to it at suitable points. The measurement schematic on a human subject is shown in Figure 6 while an actual measurement set up on a human subject is shown in Figure 7. Pieces of thin copper plates about 1cm x 3cm in size were cut and cleaned with sand paper to work as the electrodes. A connecting wire was soldered to one side of each copper plate. Conducting gel was rubbed on the side of the electrode to be placed on the skin. Two position on the chest were cleaned using isopropyl alcohol. Then each electrode was attached to the chest surface using surgical tapes.

The electrodes were fixed on the right side of the thorax around the horizontal level of the nipple so that the lower portion of the lungs is covered by the sensitive zone due to the specified electrode positions. Parameters used for this measurement were: 15 turns in primary and 30 turns in secondary for the transformer (15,30 configuration) and $R_S = 1\text{k}\Omega$ (for the V-I converter circuit in Figure 5) which drives a current of less than 1mA through the load. Firstly, the subject took a breath and held it for a while when the potential developed across the electrodes was measured using an oscilloscope. Next, the subject breathed out and held it for a while when the second potential developed across the electrodes was measured. Afterwards, using the same circuit, a variable resistor was used instead of the human body at the load to find the value of load resistances giving the corresponding values of output voltages. This value of load resistance would then equal the load impedance offered by the human body between the specified electrodes at breathe-in and at breathe-out conditions. These values would then give an estimation of typical expected real life load impedances for measurements on the lung regions of the chest and the basis of further design requirements of the instrumentation.



Figure 7. Electrode set up for measurement of impedance under breathe-in and breathe-out conditions

2.2 Study of load current variation with isolation transformer

The results of the above experiments on a human subject provided a basis for the range of load impedances to be expected from a human subject and the magnitude of variation in load impedance to be obtained due to lung ventilation. Keeping within these ranges, the performance of both the designed transformers was put under test as shown in Figure 5 for one transformer, using one section of the circuit described in Figure 3. A load resistor was connected across the secondary of the transformer and the output voltage across the load resistor was measured on an oscilloscope. The value of the load resistor was then changed to different values and the measurements as above were repeated and the results were analysed to find out the range of resistor values for which the load current remains approximately constant. The load current could be varied changing the value of R_S in Figure 5.

Firstly, a transformer (TR1) was designed with the different turns for primary and secondary coils, for experimentation. Finding out the suitable transformer turns configuration through the above experimentation, a second transformer (TR2) was designed. Figure 8 shows photographs of one of the isolating ferrite transformers made and of the ferrite core used.

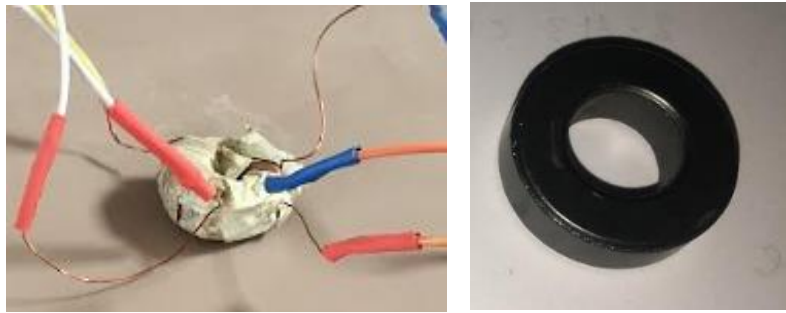

Figure 8. Fabricated current transformer (left) and Ferrite core used (right)

It was necessary to achieve a constant current across the secondary of the designed transformer for a range of load resistors in the range of 1 to 3 kilo ohms (to correspond to estimated values of load resistance on the human thorax as reported by others and as measured by us as well, described in earlier section and values given in the ‘Results’ section). Initially, the idea was to keep the number of turns same across both primary and secondary of the ferrite transformers so as to obtain the same current amplitude. However, it was difficult to achieve since some energy loss occurs in the transformers. So different transformer turns ratio were experimented with and the load current values were noted placing different values of fixed resistor across the secondary of the transformer as shown in Figure 5. Through a few trial and error, transformer configurations with 15 turns in primary and 30 turns in secondary in the first and 6 turns in primary and 60 turns in secondary in the second were chosen for further experimentation. Some measurements were also performed with 15 turns in primary and 60 turns in secondary

2.3 Resistor chain phantom for TPIM measurement

FIM essentially consists of two TPIM systems as mentioned before. A test measurement circuit was designed to simulate TPIM measurement on a volume conductor using a 3-resistor chain as shown in Figure 9. Here R_A and R_C represent the skin electrode impedances while R_B represents the bulk impedance of the body, the target to be measured.

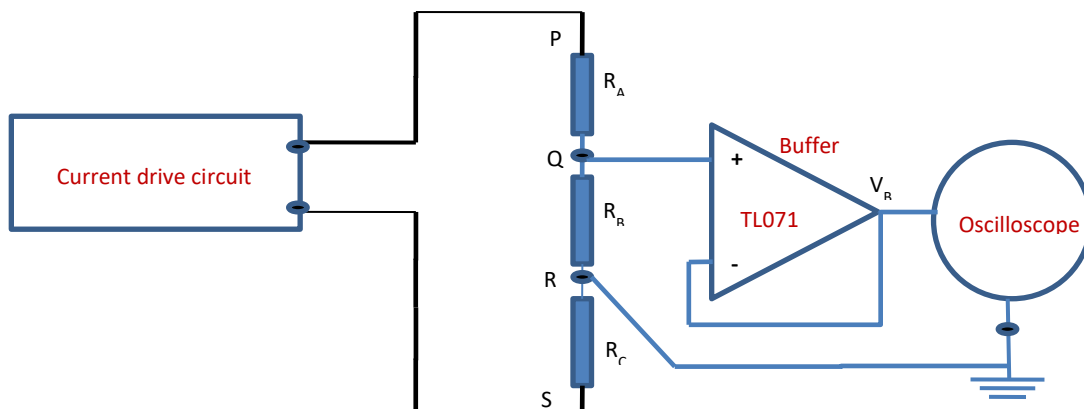

Figure 9. Block diagram showing resistor chain phantom and measurement technique

For this measurement the values of R_A and R_C taken were 999 ohms and 993 ohms respectively, as measured using a multimeter. The value of middle resistor (R_B) was varied between 150 ohms and 1 kilo-ohms. The choice of the above values were made to match the realistic values typically obtained from the thorax of the human body. The current source as shown in Figure 5 was used for the measurements. For the initial measurements the transformer had 6 turns in the primary and 60 turns in the secondary. The series resistance R_S controlling the V-I converter (Figure 5) was chosen as 1.00 k Ω . The total resistance across the whole chain $R_T (=R_A+R_B+R_C)$ was measured using a quality multimeter. The value of the middle resistor, R_B was also separately measured using the multimeter. Then the chain was connected to the current source (current drive) as shown. At first, the voltage across the whole chain, V_C was measured connecting the oscilloscope between points P and S. For this measurement, connections of the op-amp at points Q and R were taken out to rule out any loading between these two points. Here V_C represents the peak voltage of the sinusoidal waveform. Using the measured values of R_T , the value of peak current $I_C (=V_C/R_T)$ was determined. Then the op-amp buffer was connected to points Q and R and the peak voltage V_B developed across R_B was measured using the oscilloscope, as shown. Dividing this voltage by the current I_C obtained above gave the value of R_B . This calculated value was then compared to the value of R_B obtained using the multimeter measurement earlier and errors calculated. A negligible error would point to the success of the instrumentation developed.

2.4 Resistor chain phantom with non-inverting amplifier with AC coupling:

There is a chance that the output across R_B may be small. So a non-inverting amplifier with ac coupling at input was also fabricated as shown in Figure 10. Here the magnitude of the gain would be R_F/R_G and was set at 95.5 in the present experiment. Co-axial cables with appropriate shielding were employed where necessary.

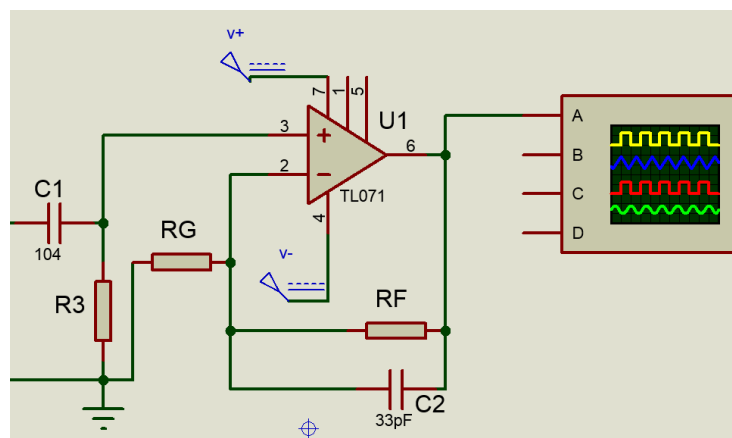

Figure 10. Circuit diagram of Non- inverting amplifier with ac coupling

2.5 Measurements on a second transformer

For the second measurement, the number of turns of the transformer were chosen as 15 turns in the primary and 60 turns in the secondary. The series resistance R_s to the V-I converter (Figure 5) was chosen as 1.00 k Ω for this study. Both the transformers (TR1) and (TR2) were used as current sources for the resistor chain in sequence. The non-inverting amplifier with AC coupling as designed in Figure 10 was used for the measurement.

3. Results and Observations

3.1 Estimation of required load impedance range from real life experiments

Following the methods described in section 2.1.3, measured with two electrodes placed on the right side of the thorax around the horizontal level of the nipple of a human subject for a transformer turns configuration of 15,60 and $R_s = 1\text{k}\Omega$, the results are given below.

Impedance at breathe-in	2.5 k Ω
Impedance at breathe-out	2.2 k Ω

3.2 Study of load current variation with isolation transformer

The results of the above sections gives values of about 2.5 k Ω to be expected from a human subject. Figure 11 shows the variation of load current against the load resistors ranging from 1.5k Ω to 3.00k Ω for the transformer configuration of (15, 60) and (6, 60). Two values of series resistances were used for the V-I converter circuit. These were 1.00k Ω and 472 Ω respectively. All these configurations were achieved winding the coils on the same ferrite core.

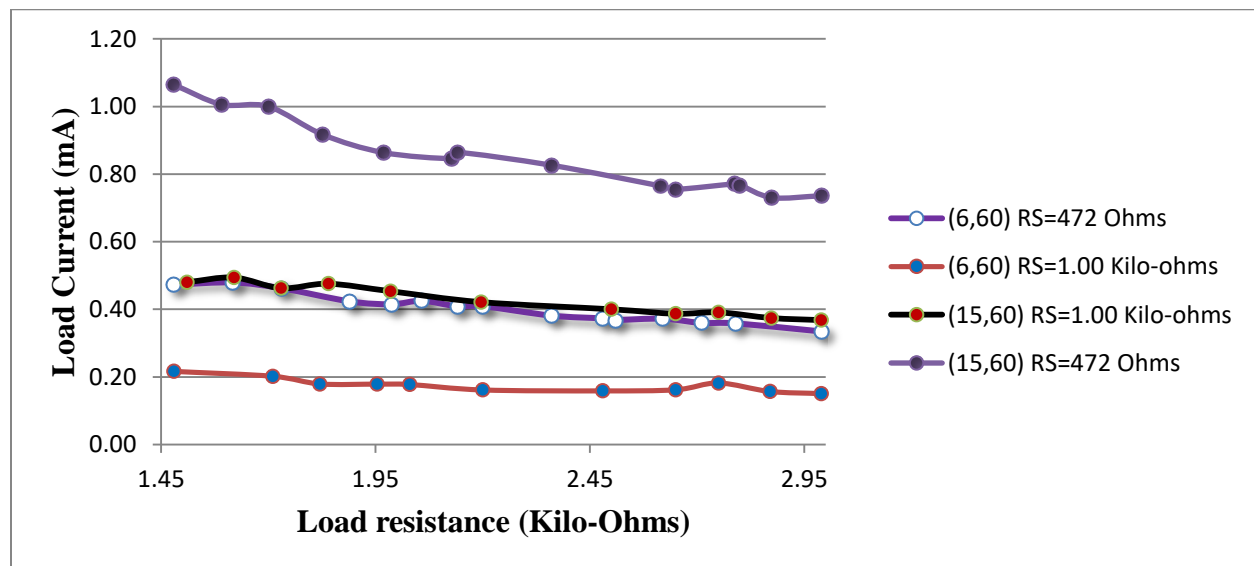

Figure 11. Load current against load resistor for various turns configuration and series resistance (R_s) of 472 Ω and 1k Ω , using one specific ferrite core.

It may be seen that the load current remains fairly constant over the measured range for the lower three curves; the corresponding values of R_S and the transformer turns configurations indicated in the figure. The performance for a turn configuration of 15,60 and $R_S=1k\Omega$ was chosen for further study. For this configuration the mean current was 0.43mA. The standard deviation and the standard deviation as percentage of mean were calculated as 0.05mA and 11.38% respectively.

For the second ferrite core, the performance was slightly different, as shown in Figure 12 for the chosen turn ratio of 15,60 and $R_S=1k\Omega$ (it is shown in an expanded scale). The current falls from maximum of 0.36mA to about 0.25mA over the range of load resistors (1.5k Ω to 3k Ω), a reduction of nearly 30 % over the whole range measured. The mean current value was calculated as 0.30 mA. The standard deviation and its percentage of mean was 0.05mA and 15.01% respectively, slightly greater than that for TR1.

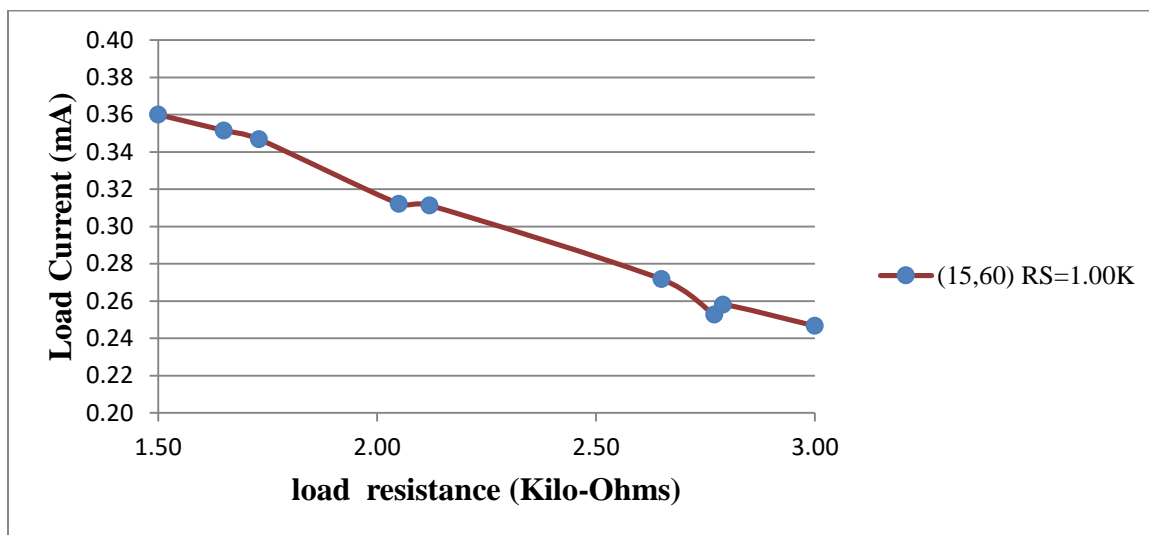

Figure 12. Load current against load resistor for 2nd transformer (TR2) with turns configuration of (15, 60) and for series resistance in V-I converter circuit, $R_S = 1k\Omega$

To achieve the same load current for both the transformers, the value of series resistor R_S in the V-I converter circuit for the second transformer circuit was reduced to 785 Ω . A comparison of the performances of the two transformers is better visualized in a combined graph, shown in Figure 13, where both show almost same values for R_L from 1.5k Ω to 2.5k Ω and diverge slightly at higher load resistances.

It may be seen that the current changed from about 0.43mA to about 0.3mA over the load resistance range between 1.5k Ω and 3k Ω . However, if we look within the practical range of the impedance change of the chest (2.2 k Ω to 2.5 k Ω) between breathe-out and breathe-in, the change in current is much lower, between 0.34mA and 0.36mA. The variation over this range with respect to the mean of 0.34mA is less than 3% and may be acceptable for the type of investigation being performed.

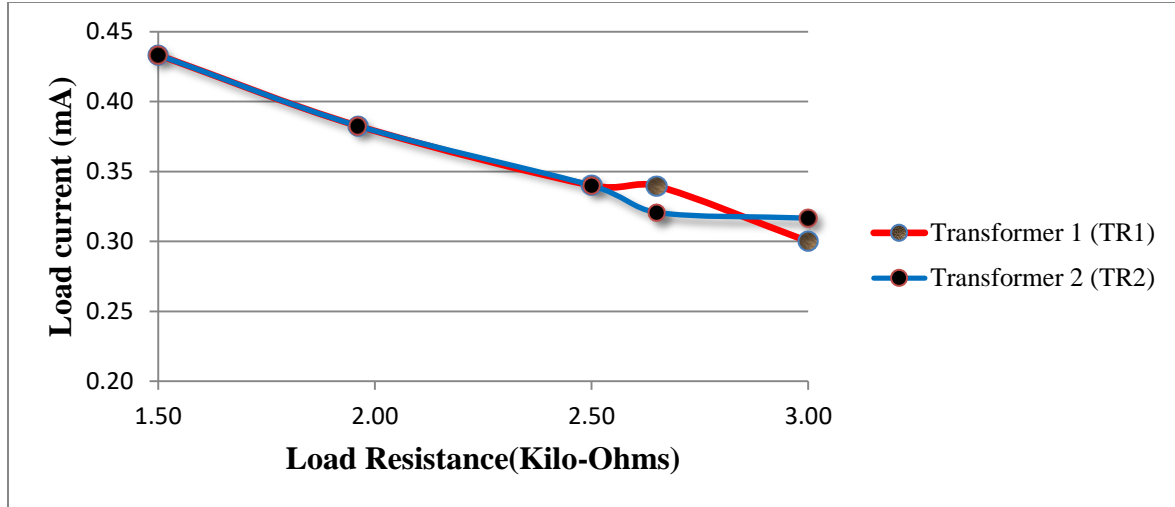

Figure 13. Load current against load resistor for both the transformers with turns configuration of (15, 60) with series resistance to V-I converter circuit, $R_s = 1.00k\Omega$ for TR1 and 785Ω for TR2. The currents are the same for R_L from $1.5k\Omega$ to $2.5k\Omega$ and diverge slightly at higher load resistances.

3.4 Resistor chain phantom and measurement with unity gain buffer

Table 3.4 presents the results of measurements carried out using the 3-resistor chain shown in Figure 9, for the transformer TR1 with the configuration of 6, 60 and with series resistance $R_s=1k\Omega$ for the V-I circuit. Here,

R_B = Resistance value measured using multimeter

R_C = Total resistance across the whole chain

V_C = Voltage across the chain without op-amp connection (to take out the loading effects)

I_C = current across secondary of the transformer as load, calculated from the measured V_C .

V_B = Output of unity gain op-amp measured of middle resistor of the chain

R_B^l = Value of middle resistor obtained from the calculation

Table 3.4. Results for resistor chain phantom using transformer TR1 with the transformer turns configuration of (6, 60) and $R_s=1.00k\Omega$

R_B (Ohms)	R_C (Kilo-ohms)	V_C (Volts)	$I_C = \frac{V_C}{R_C}$ (mA)	V_B (Volts)	$R_B^l = \frac{V_B}{I_C}$ (Ohms)	% error $(\frac{R_B^l - R_B}{R_B}) * 100$
198.3	2.19	0.38	0.17	0.03	195.95	-1.19
218	2.21	0.38	0.17	0.04	221.00	1.38
326.7	2.32	0.4	0.17	0.06	324.80	-0.58
382	2.37	0.4	0.17	0.07	385.13	0.82
238.6	2.23	0.38	0.17	0.04	246.47	3.30
463	2.46	0.4	0.16	0.07	430.50	-7.02
555	2.55	0.4	0.16	0.09	541.88	-2.36
979	2.97	0.42	0.14	0.14	990.00	1.12

The table shows good agreement for the calculated and measured values of the middle resistor placed in the chain except for one value, for $R_B = 463\Omega$, where the error is about 7%.

3.5 Resistor chain phantom and measurement with non-inverting amplifier with ac coupling

Table 3.5 shows the results for the resistor chain phantom where the unity gain buffer was replaced with a non-inverting amplifier with ac Coupling and a gain of 95.5. It was performed for the transformer configuration of 6, 60 with $1k\Omega$ for the series resistance R_S in the V-I converter circuit, and was performed for both TR1 and TR2. Here, all the abbreviations are as above except the following:

V_O = Output of Non-inverting op-amp measured of middle resistor of the chain

V_B = Voltage drop across the middle resistor of the chain, dividing V_O by the gain (95.5)

Table 3.5. Results for resistor chain phantom placing both the transformers TR1 and TR2 for turns configuration of 15, 60 with $R_S = 1k\Omega$.

R_B (Ohms)	R_C (k Ω)	V_C (Volts)	$I_C = \frac{V_C}{R_C}$ (mA)	V_O (Volts)	$V_B = \frac{V_O}{95.5}$ (Volts)	$R_B' = \frac{V_B}{I_C}$ (Ohms)	% error $(\frac{R_B' - R_B}{R_B}) * 100$
A) FOR TR1							
55.4	2.06	0.85	0.41	2.20	0.02	55.84	0.79
99.7	2.1	0.85	0.40	3.70	0.04	95.73	-3.98
B) FOR TR2							
55.4	2.06	0.7	0.34	1.80	0.02	55.47	0.13
99.7	2.1	0.7	0.33	3.10	0.03	97.39	-2.31

The table shows good agreement for the calculated and measured values of the middle resistor placed in the chain.

4. DISCUSSIONS

The specific focus of the present work was to design the circuit for FIM-6 for localized lungs study in the human body. This involves the placement of six electrodes aimed at the study of desired lung region. The design required going down to the basics so that every part of the challenge was characterized and understood. The main challenge was in the design of the two isolation transformers which should be well matched in characteristics. There was also a limitation of time as the work was performed for a Master's thesis. Therefore, some of the work was left in a stage where further improvement was possible. These would be taken up later.

The performance testing of the designed isolating transformers shows that neither of these delivers the constant current across the secondary in the strict sense. However, we could do away with the variation seen in the values of current measured across different values of load resistors since; in practical measurement the impedance change is very small. Therefore, the current across the secondary of the designed isolating transformers can be assumed to be approximately constant for the practical measurement. Due to lack of ferrite cores of variable size the experiment was restricted solely to the number of turns. The efficiency of the designed ferrite transformers could be enhanced with the machine winding of the wire which could reduce the flux loss in the core. Therefore, the performance could be improved with more experimentation on the core and the technique of winding the coils.

To obtain the constant current across the outputs of both the transformers (TR1) and (TR2) was quite difficult. In fact, it is quite impossible to achieve this with manually wound transformers. However, in practical measurement the change in body impedance is low for the variation of breathe-in and breathe-out rendering the small change in the current value. Although we got about 13% variation between breathing in and breathing out (2.5 k Ω against 2.2 k Ω), through judicious placement of electrodes, it may be possible to get variations of the order of 20%, where errors under 5% may be acceptable in clinical work on patients.

The designed current drive circuitry worked well in the ‘Resistor Chain phantom’ with a good agreement for the measured and true values of the middle resistor of the chain. The error obtained was less than 4% in most cases except one (7%) which could have occurred due to measurement errors. This could be improved through further careful studies. Again, the errors are similar whether we used a unity gain buffer or a non-inverting amplifier with a gain of about 95. Therefore, depending on the ranges of voltages obtained in a particular experiment, there is a flexibility in the choice of gains of the amplifier.

The next research-step will be the implementation of the designed circuit for FIM-6 which was developed on a prototyping ‘Breadboard’ to a printed circuit board (PCB). More experimentation on the ferrite core sizes’ will have to be made that could improve the constancy of the current over the desired range of load impedances. The performance of the designed circuit could be improved through improvement in V-I converter circuit. This could be done by replacing the floating load V-I converter circuit with the improved version of the circuit as Howland current pump, precision V-I converter etc.

The present work was taken up to develop the necessary instrumentation for the FIM-6 technique in Nepal using off-the-shelf electronic components available locally. This was also aimed at emphasising the innovation of indigenous low-cost technology in a low and medium income country (LMIC) like Nepal. FIM has the potential to benefit the people who are deprived of modern health care technology as the technique is non-invasive and of low cost. Although similar circuitry has been developed by the innovators of the technique in Bangladesh before, growing an indigenous capability in every low and medium income country is of utmost importance. This can provide equipment that suits people’s behaviours and habits adapting to local weather and power

line conditions. Besides, equipment produced locally can be distributed at considerably low cost compared to imported ones and can be maintained and repaired locally, giving a long service life, and consequently, reducing e-waste.

Acknowledgements

The authors gratefully acknowledge the International Science Programme of Uppsala University for providing general support to the FIM research in Bangladesh and for a fellowship to one of the authors (TK) for visiting Bangladesh during an important phase of the work.

References

1. Rabbani K S, Sarker M, Akond M H R and Akter T, *Focused Impedance measurement (FIM) - A new technique with improved zone localization*. In: Electrical Bioimpedance methods, Annals of the New York Academy of Sciences, Volume 873, p. 408-420, 1999.
2. K S Rabbani and M A S Karal, *A new four-electrode Focused Impedance Measurement (FIM) system for physiological study*, Annals of Biomedical Engg (Springer, US), vol 36, no.6, p.1072-1077, 2008.
3. K Siddique-e Rabbani, *Focused Impedance Method: Basics and Applications*. In: Simini F., Bertemes-Filho P. (eds) Bioimpedance in Biomedical Applications and Research. Springer, Cham, p. 137-185, 2018.
4. K Siddique-e Rabbani and M Abdul Kadir, *Possible applications of Focused Impedance Method (FIM) in biomedical and other areas of study*, Bangladesh Journal of Medical Physics, Vol: 4, No.2, p.67-74, 2011.
5. Kadir M A, Baig T N and Rabbani K S, *Focused impedance method to detect localized lung ventilation disorders in combination with conventional spirometry*, Biomedical Engineering: Applications, Basis and Communications, **27**, 1550029, 2015.
6. V. Lakshminarayanan and Balakrishnan.P.A, *Analysis and Design of Ferrite Core Transformer for High Voltage, High Frequency which is used in Ozonators*, International Journal of Engineering and Applied Sciences. vol 2, no.1, p.34-44, 2013.