

## Power point tracker mounted solar powered DC induction cooker

S. M. N. Shams, F. Sultana, A. Saha and M. A. Haque

Institute of Energy, University of Dhaka, Dhaka-1000, Bangladesh

### ARTICLE INFO

Received: 09 April 2023

Revised: 31 July 2023

Accepted: 08 August 2023

eISSN 2224-7157/© 2023 The Author(s).  
Published by Bangladesh Council of  
Scientific and Industrial Research  
(BCSIR).

This is an open access article under the  
terms of the Creative Commons Non  
Commercial License (CC BY-NC)  
(<https://creativecommons.org/licenses/by-nc/4.0/>)

DOI: <https://doi.org/10.3329/bjsir.v58i3.65550>

### ABSTRACT

Induction method of cooking is extensively used for its high effectiveness and safe way of cooking. This paper provides presentation on design and implementation of a solar powered DC induction cooker. The energy from the sun is used as the power source of the cooker. When solar power is not available, the cooker can also be operated by battery. The design of the proposed induction cooker has been developed by modifying conventional AC induction cooker. The main purpose of this cooker is to serve the rural areas where electricity is not always available. Incremental conductance (IC) technique has been used as the procedure of the MPPT which confirms charging of battery by taking in maximum power from the PV panel and the proposed induction cooker will be operated by these batteries. Time taken for cooking different food items has been studied and it is observed that this induction cooker can serve the purpose of cooking for a small family satisfactorily.

**Keywords:** MPPT; Incremental conductance; Induction cooking; Battery; Quasi resonant; IGBT; Power level; Duty cycle; Solar panel; Arduino uno

### Introduction

Cooking is one of the significant human activities as food is our one of the basic needs of life. Most of the people in rural areas use wood, biomass and kerosene for cooking. This cooking process is very inefficient and generates a lot of smoke which causes indoor air pollution and different diseases. It also causes deforestation and environmental hazards in the country (Bassily and Colver, 2004). A small number of rural people use LPG for cooking purpose which is also very costly. Moreover, the supply of LPG is decreasing day by day. Cooking with electricity can be a great solution to this problem. Among different kinds of cooking, induction method of cooking is commonly used because of its cleanliness, high efficiency, safety and high performance (Acero *et al.* 2008).

Although, induction cooking eliminates health concerns, the environmental impacts depend on the methods of electricity generation. Cooking with solar energy is the safest, environmentally friendly and convenient way to cook. It can play a major role in solving future energy crisis problems in least developed countries like Bangladesh.

Solar PV technology can be used for induction cooking with a battery backup as a storage medium. Due to the rapid decrease of the cost of PV panel, solar powered induction cooking has become cost competitive solution. In recent years, many studies have been done on improving induction cooking technologies. FEM simulation model of conventional induction cooker built with circuit and coil has found that the magnetic field generated is uneven and localized resulting poor performance (Meng *et al.* 2009). Forest *et al.* (2000) have experimented on the effects of pan material on the cooking purpose. The study between different types of converters has been done by Vishnuram *et al.* (2020), studied five types of pan material and concluded that increasing switching frequency reduces coil cost and increase effectiveness of the cooker. Sibiya and Venugopal (2017) have experimented on the modes of switching. Liang (2017) examined a device which is heated using induction method with half bridge resonant inverter simulation.

\*Corresponding author's e-mail: [shaeti123@gmail.com](mailto:shaeti123@gmail.com)

An induction cooker has been designed in (Ekkaravarodome *et al.* 2013) that presents weak heating energy saving with high speed cooking and with many ranges of temperature. Fire hazards of different induction cookers have been reviewed (Arthur and Fong 2013). Jain *et al.* (2015) investigated the optimization possibilities of a quasi-resonant induction cooker. Authors have claimed that the performance of the coil can be enhanced by minimizing the resistance of the coil and the IGBT can be optimized by reducing the tail current in soft switching mode. Adhikari *et al.* (2017) have designed a solar based quasi resonant dc induction cooker and simulated in Proteus but this was not implemented in hardware. The model prepared in Thirithandar *et al.* (2009) of induction cooker has been designed to operate at an output of 500W and with a frequency of 24 KHz. Authors have used a series resonant inverter in the cooker and it was only designed for alternating current (AC). Weber (2015) designed an induction stove of 500W to 1KW with 24V input from battery but efficiency of the cooker was low due to its simple design and control system. A solar based DC induction cooker has been implemented with half bridge inverter (Sibiya and Venugopal, 2017). The limitation of the study is that the power level was too low to cook foods properly.

From the above literature review it is seen that there is no model of induction cooker which is powered by DC voltage and works satisfactorily. The proposed system describes an MPPT based solar induction cooker which can be operated by 48V battery and the inverter topology that has been used here is quasi resonant topology which gives the highest efficiency among all the inverter topologies. Incremental conductance method has been used to trace out the maximum power point of the panel.

**Materials and methods**

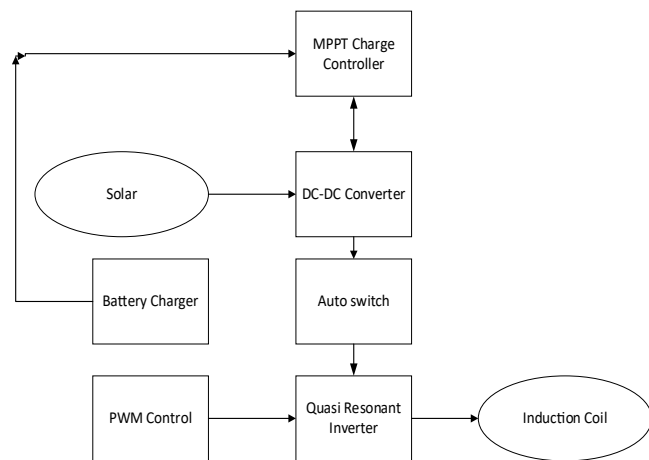
*Block diagram of the system*

Figure 1 shows the complete block diagram of the solar power-driven dc induction cooking system. An MPPT based solar charge controller has been designed to collect maximum power from the solar panel and deliver this power to the cooker and the battery. The design has included an induction coil which takes power from solar panel and battery using quasi resonant inverter topology. The temperature of the cooker can be controlled by controlling the power level.

*Maximum power point tracking (MPPT)*

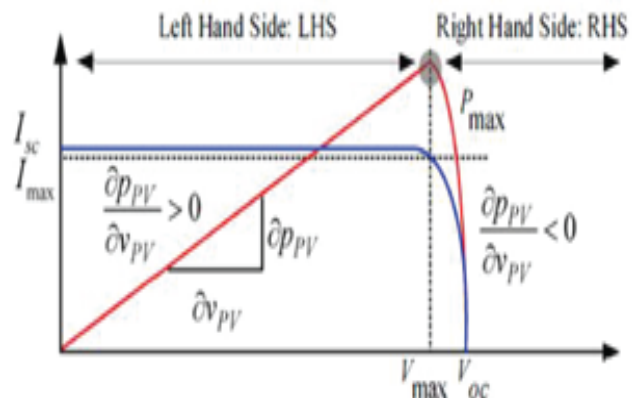
In this paper, incremental conductance (IC) algorithm has been used for maximum power point sensing because IC method is one of the efficient methods among all the MPPT techniques which is shown in Fig. 3. IC attempts to improve

the tracking time and produces more energy on a vast irradiation on changing environment (Xuesong *et al.* 2010). The calculation of maximum power point can be done by using the connection between  $dI/dV$  and  $-I/V$ . If  $dP/dV$  is negative then maximum power point tracker (MPPT) lies on the right side of current position and if the MPP is positive then the MPPT is on left side. If MPP lies on right side,  $dI/dV < -I/V$  and then the PV voltage must be decreased to reach the MPP (Xuesong *et al.* 2010).



**Fig. 1. Block diagram of the proposed system**

When voltage increases power also increases and it is seen from Fig. 2 that when PV panel operates on the left side of the maximum power point, power increases and when panel operates in the right of MPP with the decrease of voltage power reaches to maximum. So, perturbation will be same when  $dP/dV > 0$  and vice versa. The process should continue until  $dP/dV=0$ .



**Fig. 2. I-V and P-V curve and maximum power point of PV module IC algorithm is seen on Fig. 3 (Vinodhkumar *et al.* 2012)**

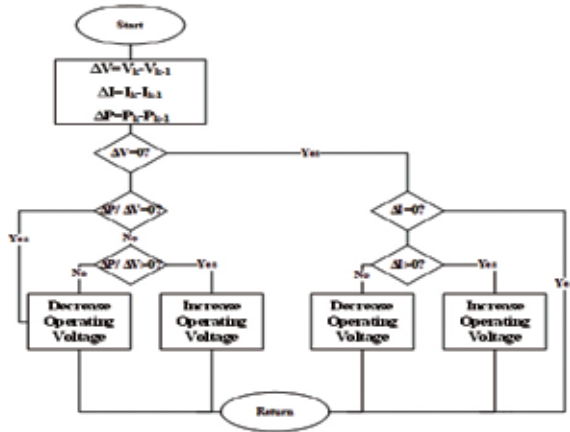


Fig. 3. Incremental conductance flowchart

*Principle of induction cooker*

Induction heating refers to the procedure of heating by electromagnetic induction that creates eddy current inside the cooking pot. The generated resistance leads to joule heating. An alternating current with high frequency passes through the coil of the induction cooker (Viriya *et al.* 2002). The frequency of the alternating current relies on the switching frequency of the IGBT. The coil of the induction cooker acts as a primary and the bottom layer of the pot acts as a secondary coil. So, the whole system is working like a transformer. The working principle of the induction cooker is shown in Fig. 4 and 5.

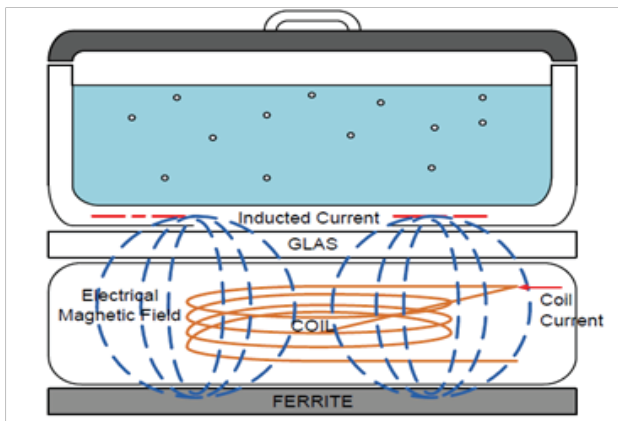


Fig. 4. Scheme of an induction cooking

Eddy current induced in the conductor generates heat. The quantity of heat produced follows the joule's law of heating which is equation 1:

$$Q = P = R \cdot i^2 = V \cdot i \dots\dots\dots(1)$$

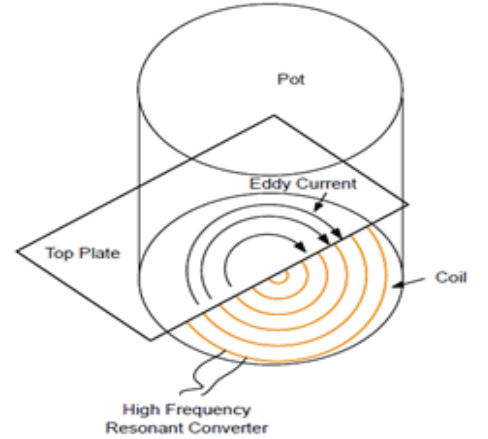


Fig. 5. Induction current at the bottom of the pot

Fig. 5. Induced current beneath the pot, where Q and P [in Watt] represent the power being converted from electrical energy to thermal energy, I [in Amps] is the current that passes through the conductor (For this particular case, the eddy current), V [in Volts] is the voltage drop across the component (e represents the electromotive force here) and R (in Ohms) is the equivalent resistance of the conductor.

*Quasi-resonant topology*

Among different converters quasi resonant converter is used most in case of induction cooker because it requires only one IGBT for switching. It is considered as a good conciliation between cost and energy transformation effectiveness. It is very usual for single burner cooker (Jain *et al.* 2015). Fig. 6 shows the proposed topology.

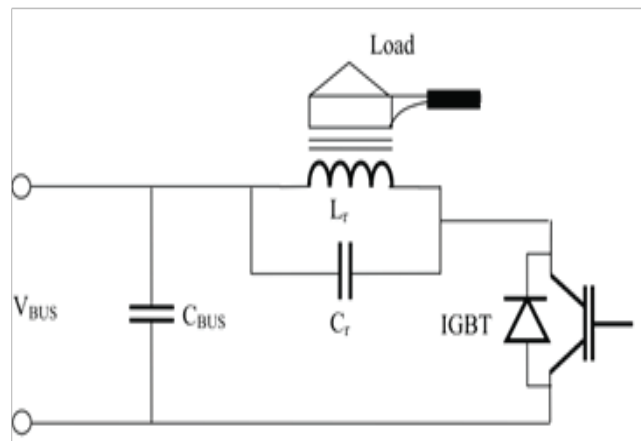


Fig. 6. Quasi resonant topology used for induction heating system

By changing the duty cycle the power level of the induction cooker can be controlled. For a certain pot maximum power

level and maximum main voltage of the switch and resonant capacitor can be calculated from QR theory and approximated by the equation no 2-5.

$$V_{res} = \sqrt{\frac{2 \cdot E}{C}} \dots \dots \dots (1)$$

$$E = \frac{1}{2} L \cdot I_{pk}^2 \dots \dots \dots (1)$$

$$I_{pk} = T_{ON} \cdot \frac{V_{dc-bus}}{L} \dots \dots \dots (1)$$

$$V_{res} = \frac{T_{ON} \cdot V_{dc-bus}}{\sqrt{LC}} \dots \dots \dots (1)$$

**Table I. Circuit parameters of MPPT**

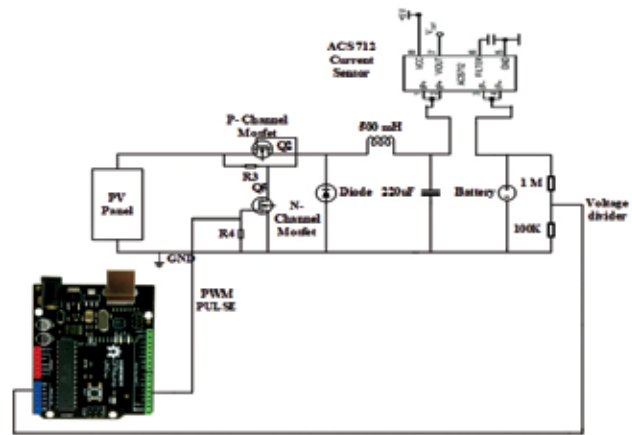
Whereas, E signifies the energy stored into the inductive part of the load during the  $T_{ON}$  phase. The peak current is proportional to  $T_{ON}$ ,  $V_{dc-bus}$ , resonant voltage  $V_{res}$  can be expressed in terms of  $T_{ON}$  and  $V_{dc-bus}$ , usually  $T_{ON}$  is kept constant throughout the mains semi period.  $T_{ON}$  can be set by PWM driving signal.

*MPPT Charge controller*

The proposed MPPT of this paper is based on DC-DC Buck Converter. The main MOSFET switch is a P-Channel MOSFET (IRF-9540). In order to drive this MOSFET a Low side N-Channel MOSFET (IRF-540) is used. This is called a High Side P-Channel drive and Low Side N-Channel drive. Fig. 7 shows that the gate of the P-Channel is connected to the drain of the N-Channel MOSFET. The PWM signal goes to the gate of the N-Channel. The positive terminal of the PV Panel is connected to the source of the P-Channel and negative terminal is connected to the ground. A current sensor (ACS-712) has been used to sense the current of the output circuit. A voltage divider has been used to sense the output voltage of the battery. The Incremental conductance MPPT code has been added to the Arduino UNO to calculate the maximum amount of power that the PV source can give. Table I shows the circuit parameters of MPPT. Circuit Parameters of MPPT

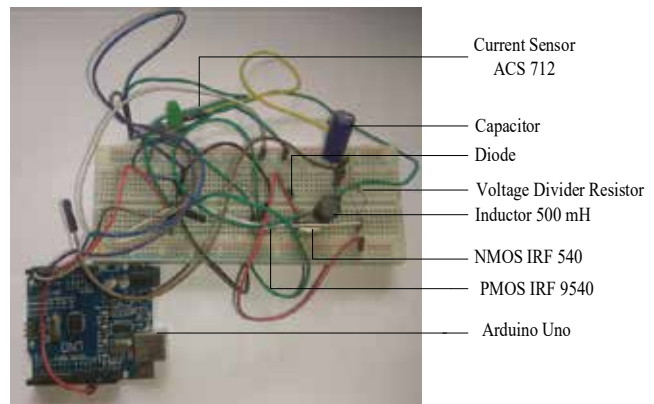
**Table I. Circuit Parameters of MPPT**

S. No.	Parameters	Values
1	Solar Panel	500 W
2	Open circuit Voltage of Solar panel	72 V
3	Solar Panel Short Circuit Current	15 A
4	P-Channel MOSFET	IRF 9540
5	N-Channel MOSFET	IRF 540
6	Inductor	500 mH
7	Capacitor	220 uF
8	Switching Frequency	31.6 KHz
9	Current Sensor	ACS 712
10	Battery	48 V,80Ah

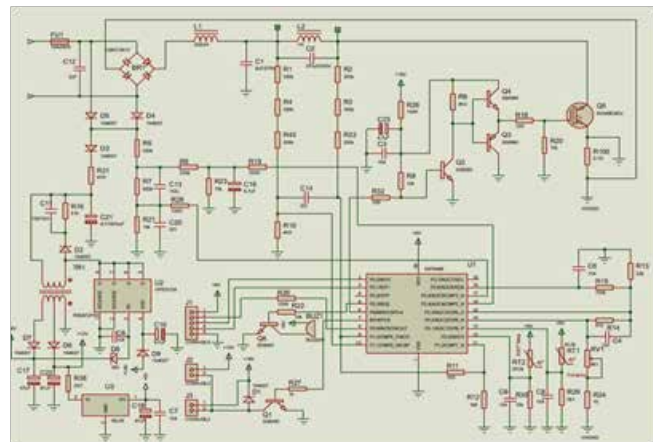


**Fig. 7. Circuit Diagram of MPPT Charge Controller (Saha et al. 2019)**

The circuit diagram of MPPT after hardware implementation is shown in Fig. 8.



**Fig. 8. Hardware implementation of MPPT (Saha et al. 2019)**



**Fig. 9. Circuit diagram of conventional induction cooker (Sibiya and venugopal, 2017)**



### Induction Cooker

To design the proposed induction cooker the conventional circuit of AC induction cooker has been used. Fig. 9 represents circuit diagram of conventional induction cooker which is operated by 220 V AC power supply. As shown in the circuit a full bridge rectifier is used to alter the AC supply into DC. So, the main circuit works on DC.

From this it can be understood that, the cooker can be operated with DC voltage. As the output of solar panel and battery is DC, the induction cooker can be functioned by both the solar panel and battery. The proposed induction cooker in this paper is based on this theory. For operating the induction cooker with DC voltage, the design of the conventional circuit is modified.

The proposed circuit does not require rectifier as the voltage source is DC. As shown in Fig. 9 the conventional circuit uses R1, R2, R3, R4, R43 and R33 resistors as voltage divider in order to send the voltage to microcontroller. If 48V DC is supplied instead of 220V AC because of these resistors' microcontroller receives voltage in microvolt range which is very difficult to sense. So, the proposed system uses resistors of small values instead of this resistor so that the microcontroller senses the voltage properly. Rest of the remaining circuit remains unchanged. The microcontroller used in the proposed design is S3F84B8. It is a newly developed Samsung's microcontroller. Fig. 10 represents the circuit diagram of proposed solar based DC induction cooker after redesigning the circuit. The resistors marked in the figure are eliminated while designing the circuit for 48V DC. Fig. 11 shows the hardware of the circuit of the proposed induction cooker. Resistors indicated in the figure are replaced by small valued resistors so that the proposed induction cooker can be operated by small voltage. This proposed induction cooker is operated by Solar PV Panel or 48V DC battery. In order to operate the induction cooker properly, minimum voltage is required 48V DC. Otherwise, the cooker will not run. The cooker coil takes maximum 5.6 A current. In order to cook food by this cooker for a small family (3-4 persons), minimum number of hours required will be 5 approximately which is experimentally calculated by the proposed cooker. In order to operate the cooker at its maximum power solar panel has been connected via battery.

The system is designed in such a way that by charging the battery once, cooker can be operated for two days (average 5 hours daily). So, battery size is required  $10h \times 8.3A = 83Ah$ . Four 12V, 80Ah batteries connected in series have been used to operate the cooker. In order to charge the batteries a 500W panel has been used. The open circuit voltage of the panel is 72V and short circuit current is 15A. Using an MPPT circuit

between solar panel and battery, the battery can be charged with approximately 12A during peak sun hour. So, number of hours required to charge the batteries are approximately  $80Ah/12A = 6$  hour 40 minutes.

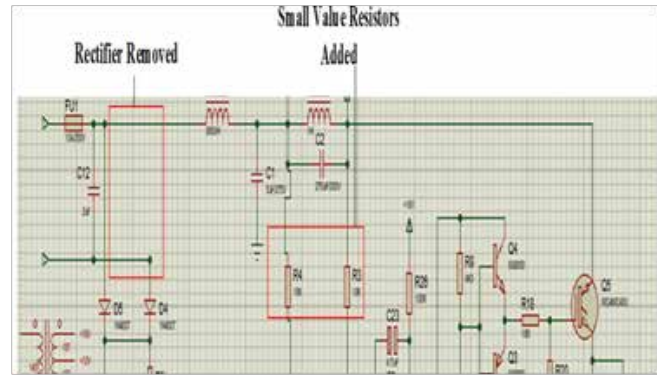


Fig. 10. The circuit diagram of proposed induction cooker

Fig. 12 shows the coil of the proposed induction cooker. The number of turns of the coil is 24. After integrating the modified circuit and the induction coil, solar powered dc induction cooker is ready for operation. Fig. 13 shows the designed induction cooker. As shown in the figure, the power of the induction cooker is measured by wattmeter. A control circuit is used to change the power level of the cooker. A fan is used to protect the circuit from overheating.

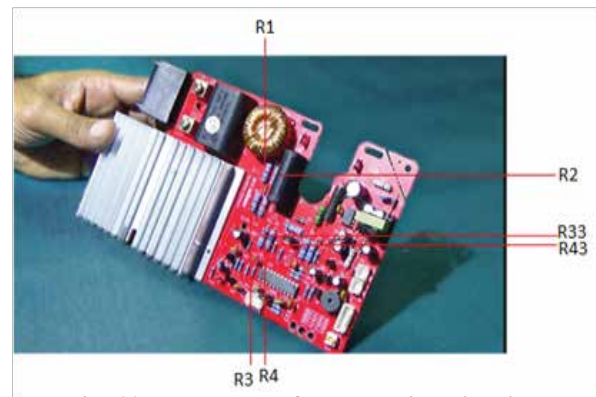
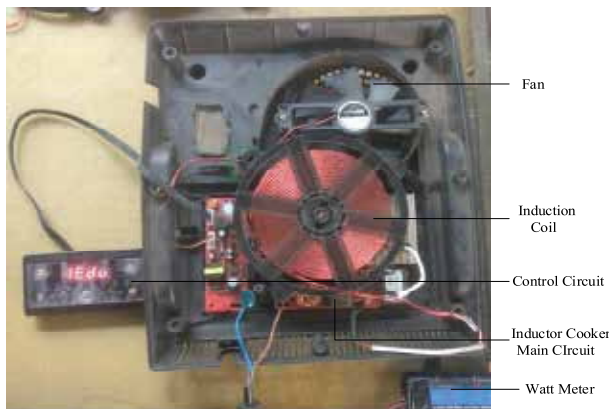


Fig. 11. Hardware of the working circuit



Fig. 12. Coil of the Induction cooker



**Fig. 13. Designed solar based DC induction cooker**

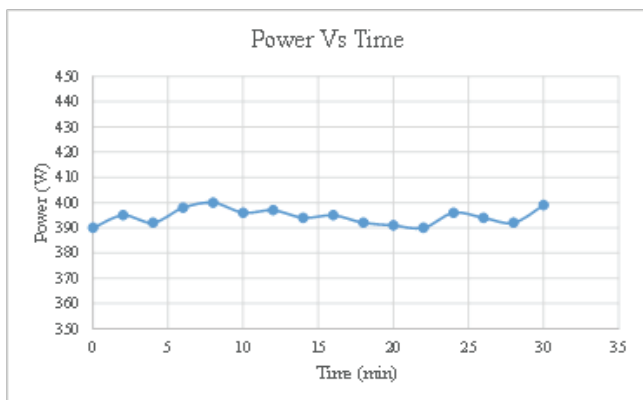


**Fig. 14. Experimental setup of induction cooker**

**Results and discussions**

*MPPT*

The purpose of using maximum power point tracking (MPPT) circuit is to charge the batteries by taking maximum power from the solar panel. Solar Panel used in this experiment is of 1250 W. It is seen from Fig. 15 that power



**Fig. 15. Power VS Time graph of MPPT**

remains in the maximum point during the whole time of the experiment. This shows the efficiency of the MPPT. The IC method would be more efficient than P and O method for MPPT. The future scope of this paper will be the comparison between two methods of MPPT. Power vs. Time graph is shown in this figure.

*Induction cooker*

Proposed induction cooker can be operated at six power levels. Different power levels indicate different ranges of power. By increasing the duty cycle ratio power level can be increased. Table II shows the voltage, current and power at different power levels. The power increases gradually from 35W to 220W by increasing the duty cycle ratio.

**Table II. Voltage current and power at different power levels**

Power Level	Voltage (V)	Current (A)	Power (W)
1	48.8	1.38	67.7
2	48.34	2.86	138.6
3	47.92	4.57	220.3
4	47.3	6.37	300
5	47	7.2	350.4
6	46.3	8.3	391.1

Power levels change due to the changing of duty cycle of the IGBT gate voltage. In order to study the performance of the cooker IGBT gate voltage wave form has been observed. An oscilloscope is connected to the induction cooker circuit to see the wave form of the IGBT gate voltage and the switching frequency. Positive terminal of the oscilloscope is connected to the gate terminal in IGBT and negative terminal is connected to the source terminal of IGBT. Fig. 16 shows the IGBT gate voltage wave form at power level 1. Here duty cycle ratio is 24.43% (+Duty from figure). With the increase of power level duty cycle increases and duty cycle ratio is 61.5% at power level 6 which is shown in Fig. 17. It is seen that with the increase of duty cycle power level increases.

Same food items were cooked in gas stove and ac induction cooker (2000W) in order to compare the time required for cooking among gas stove, ac induction cooker and designed cooker. Table III shows the comparison of the times taken by all three cookers. It is seen from the table that even though the induction cooker has taken more time than gas stove and ac induction cooker for cooking, the difference is not huge. The foods were cooked within decent time duration and it can be used for a family.



Fig. 16. IGBT gate voltage waveform at power level 1



Fig. 17. IGBT gate voltage waveform at power level 6

Table III. Time Required for Cooking of Different Item on Induction Cooker and Gas Stove

SI. No	Items	Quantity	Duration in Gas Stove (min)	Duration in AC Induction cooker (min)	Duration in Proposed Induction Cooker (min)
1	Water Boil	1000 ml	10	12	20
2	Egg Boil	1 piece	10	12	15
3	Instant Noodles	1 packet	6	6	8
4	Rice	150 gm	15	16	18

The conventional induction cookers in the market cannot be operated on DC supply. The induction cooker of this paper can be connected with a battery and solar panel directly. It can solve cooking problems in remote areas of Bangladesh where heavy load shedding occurs and can lessen the pressure of energy demand of the national grid.

### Conclusions

This paper presents a novel system where an Induction Cooker that is powered by photovoltaic panel or battery has been implemented. Quasi Resonant inverter topology is used to drive the IGBT. By using MPPT circuit battery has been charged within 7 hours approximately. This battery is used to run the cooker for 2 days. Different items of foods have been cooked by the cooker to evaluate the performance and the cooking times are compared. Proposed cooker has been designed considering rural areas where electricity is not available. As the supply of gas is decreasing, proposed cooker can be a good alternative to gas stove. There is a scope of study to increase the power level furthermore.

### References

Saha A, Sultana F, Haque MA and Nasif SSM (2019), "Design of MPPT mounted Solar Based Double Coil DC Electric Cooker with Smart Temperature Control Device," *5<sup>th</sup> International Conference on Advances in Electrical Engineering (ICAEE)*, Dhaka, Bangladesh, pp 212-217, DOI: 10.1109/ ICAEE48663. 2019. 8975451.

Acero J, Burdío JM, Barragan LA, Navarro D, Alonso R, Garcia JR and Garde I (2008), The domestic induction heating appliance: An overview of recent research. *Twenty-Third Annual IEEE Applied Power Electronics Conference and Exposition*. <https://doi.org/10.1109/apec.2008.4522791>

Adhikari B, Shrestha J and Shakya S (2017), Design and Simulation of a Solar Electricity Based Induction Cooker using Quasi Resonant Topology. Retrieved from [www.semanticscholar.org](http://www.semanticscholar.org) website: <https://www.semanticscholar.org/paper/Design-and-Simulation-of-a-Solar-Electricity-Based-Adhikari-Shrestha/d9aa0cde597d018e0cbca5bb502e07937865c92c>

Arthur KKW and Fong NKF (2013), Experimental Study of Induction Cooker Fire Hazard. *Procedia Engineering*, **52**: 13-22. <https://doi.org/10.1016/j.proeng.2013.02.098>

Bassily AM and Colver GM (2004), Modelling and performance analysis of an electric heater, *International Journal of Energy Research* **28**(14): 1269-1291. <https://doi.org/10.1002/er.1029>



- Ekkaravarodome C, Charoenwiangnuea P and Jirasereeamornkul K (2013), The simple temperature control for induction cooker based on class-E resonant inverter. *10<sup>th</sup> International Conference on Electrical Engineering/Electronics, Computer, Telecommunications and Information Technology*. <https://doi.org/10.1109/ecticon.2013.6559634>
- Forest F, Laboure E, Costa F and Gaspard JY (2000), Principle of a multi-load/single converter system for low power induction heating, *IEEE Transactions on Power Electronics* **15**(2): 223-230. <https://doi.org/10.1109/63.838094>
- Jain A, Mallik R, Catalisano G and Abbatelli L (2015), IGBT over voltage protection scheme in quasi resonant induction heating applications. *Annual IEEE India Conference (INDICON)*. Presented at the Annual IEEE India Conference (INDICON), India. <https://doi.org/10.1109/indicon.2015.7443127>
- Liang HC (2017), Circuits analysis of inductive heating-device with half-bridge resonated inverter. Retrieved April 7, 2023, from <https://www.semanticscholar.org/paper/Circuits-analysis-of-inductive-heating-device-with-Chun-Liang/696843ed018c875b0e1c09e536ec3f7c79fc1321>
- Meng LC, Cheng KWE and Chan KW (2009), Heating performance improvement and field study of the induction cooker: 2009 3rd International Conference on Power Electronics Systems and Applications, PESA 2009. *2009 3rd International Conference on Power Electronics Systems and Applications, PESA 2009*. Retrieved from <https://research.polyu.edu.hk/en/publications/heating-performance-improvement-and-field-study-of-the-induction-cooker>
- Putri RI, Wibowo S and Rifa'i M (2015), Maximum Power Point Tracking for Photovoltaic Using Incremental Conductance Method, *Energy Procedia* **68**: 22-30. <https://doi.org/10.1016/j.egypro.2015.03.228>
- Sheikhian I, Kaminski N, Vos S, Scholz W and Herweg E (2013), Optimisation of quasi-resonant induction cookers. *15<sup>th</sup> European Conference on Power Electronics and Applications (EPE)*. <https://doi.org/10.1109/epe.2013.6631837>
- Sibiya B I and Venugopal C (2017), Solar Powered Induction Cooking System. *Energy Procedia* **117**: 145-156. <https://doi.org/10.1016/j.egypro.2017.05.117>
- Thirithandar S, Saldanah C and Moe W (2009), Design and Construction of Power System for Induction Heating (IH) Cooker Using Resonant Converter. Retrieved April 7, 2023, from [www.semanticscholar.org](http://www.semanticscholar.org) website: <https://www.semanticscholar.org/paper/Design-and-Construction-of-Power-System-for-Heating-Thirithandar-Saldanah/4c33afb5516570b95d709dde81e70f52e8bc0853>
- Vinodhkumar GMs and Vince RJ (2012), Performance Enhancement in PV System using Intelligent Controller based MPPT Controller. *Dr. M. Sasikumar / IOSR Journal of Engineering (IOSRJEN)* [www.iosrjen.org](http://iosrjen.org) **2**(2): 284-287. Retrieved from [http://iosrjen.org/Papers/vol2\\_issue2/Q022284287.pdf](http://iosrjen.org/Papers/vol2_issue2/Q022284287.pdf)
- Viriya P, Sittichok S and Matsuse K (2002), Analysis of high-frequency induction cooker with variable frequency power control. *Proceedings of the Power Conversion Conference-Osaka (Cat. No.02TH8579)*, 3. IEEE. <https://doi.org/10.1109/pcc.2002.998196>
- Vishnuram P, Ramachandiran G, Ramasamy S and Dayalan S (2020), A comprehensive overview of power converter topologies for induction heating applications. *International Transactions on Electrical Energy Systems*, **30**(10): <https://doi.org/10.1002/2050-7038.12554>
- Weber DJ (2015), Design of a battery-powered induction stove. Retrieved April 7, 2023, from [dspace.mit.edu](http://dspace.mit.edu) website: <http://hdl.handle.net/1721.1/100618>
- Xuesong Z, Daichun S, Youjie M and Deshu C (2010), The simulation and design for MPPT of PV system Based on Incremental Conductance Method. <https://doi.org/10.1109/ICIE.2010.170>