



Enhancing usable appliances for energy integration with solar power

S. C. Debnath^{1*}, N. Yeasmin¹, A. Siddika¹, M. Sultana¹, M. S. Bashar¹, M. Rahaman¹, S. Islam² and
S. Tabassum^{1*}

¹Institute of Energy Research & Development (IERD), Bangladesh Council of Scientific and Industrial Research (BCSIR), Dhaka-1205

²Industrial Physics Division, BCSIR Dhaka Laboratories, Bangladesh Council of Scientific and Industrial Research (BCSIR), Dhaka-1205

ARTICLE INFO

Received: 30 April 2023

Revised: 08 September 2023

Accepted: 29 September 2023

eISSN 2224-7157/© 2023 The Author(s).
Published by Bangladesh Council of
Scientific and Industrial Research
(BCSIR).

This is an open access article under the
terms of the Creative Commons Non
Commercial License (CC BY-NC)
(<https://creativecommons.org/licenses/by-nc/4.0/>)

DOI: <https://doi.org/10.3329/bjsir.v58i4.65689>

ABSTRACT

Solar energy is one of the prospective sources of Bangladesh which can meet energy demand and provide a contribution to sustainable development goals. Besides the use of the solar system in electricity generation for households, some other sectors are also using photovoltaic in irrigation, street lighting, water pumping, etc. This article introduces the idea of some other applications of solar photovoltaic systems. Here, solar backpack, farm hat, and grass cutter are designed and fabricated to utilize solar energy for recharging storage systems as well as being operated directly in the daylight. Solar powered charging backpack uses a solar panel of 5 W/17 V capacity at the front side of the backpack with a 5 V output voltage which can charge mobile phone or rechargeable battery. The results clearly showed that it is capable to charge the phone and the charging level of mobile phone successfully raised from 22% to 88% within 5 hours by putting it in direct sunlight on cloudy weather. This article also explained solar farm hat which is very simple but effective for our farmers. Light weight solar powered fan (1.92 W/12 V DC) placed on the top of the hat which is used to cool their face. Lighting (4 ultra-bright 3 V LEDs) and battery charging system are also attached in this system. Further, Solar powered grass cutter machine is designed and developed mainly considering the air pollution using fossil fuels which can also be a usable solar energy appliances. These appliances can keep role to build a eco-friendly system.

Keywords: Solar energy; Solar backpack; Solar farm hat; Solar grass cutter; Printed circuit board

Introduction

The energy demand is increasing day by day to meet social needs. The demand is not only limited to grid electricity for home or commercial uses but also for many other applications like street lamps, electric vehicles, etc. Besides, the demand for electronic devices is increasing tremendously with the improvement of civilization. Most of the energy that powers society comes from fossil fuels, non-renewable energy sources, which are not adequate and also produce large carbon emissions. To reduce this problem, we can use renewable energy sources which are environment friendly and unlimited. Among the different types of renewable energy sources (solar, wind, hydro, etc.), Bangladesh becomes one of the highest potential sources for solar

energy. Solar radiation comes from the sun which is capable of producing heat and generating electricity. The amount of solar energy that falls on the earth is enough in excess to manage the world's anticipated energy demand. In the 21st century, solar power is becoming a more attractive renewable energy source for its unlimited power supply and non-polluting nature. It is well known that the time is not so far when all fossil fuel sources will be completely exhausted. So, solar power can be used as one of the prime alternative sources to avoid an energy crisis in the nearby future. It is calculated that the energy received from the sun in one hour can fulfill the whole world's energy demand for 1 year (Shaikh *et al.* 2017).

*Corresponding author's e-mail: samia@bcsir.gov.bd

Bangladesh, being situated at 23°43'N and 90°26'E which in a very favorable position in respect of the availability of solar energy (Tabassum *et al.* 2019). According to a metrological survey, 200 days on average per year are sunny, and as such attempts should be made to utilize this source of energy for different purposes. In our daily life, we use numerous high-tech devices and tools to make our life easy and comfortable. As these devices consume low power so, this power can be easily harnessed from sunlight using solar cells incorporated with these devices. There are so many applications to utilize solar energy from large scales such as generating electricity for home and industry to small-scale applications such as solar-powered backpack for charging mobiles, laptops, and other electronic devices (Adejuyigbe *et al.* 2013). Apart from solar backpack, solar energy can also use in LED flashlights, Bluetooth speakers, rechargeable batteries, and so on.

Now a day's solar-powered backpack is becoming more popular among people both in rural and urban areas when they are outside their homes during traveling or hiking and where they can easily get solar power to charge their mobile phones and electronic accessories (Mudi, 2020). Generally, a solar backpack contains a solar panel set up on the top side of the backpack which collects solar energy and stores it in a battery so that it can charge mobile phones, laptops, tablets, and other electronic devices when necessary (BAŞOĞLU and ÜSTEK, 2021).

Similarly, a solar grass cutter is an important machine to enhance the beauty of home lawns and gardens by trimming the grass or lawn at an even length without any hassle (Athina *et al.* 2021; Mudda *et al.* 2018). Solar-based grass cutter has more advantages than other oil or gas-based source of power. By incorporating solar panels on this manually handled machine, one can save engine oil/gas. It also reduces costs by saving engine oil and making the environment clean from carbon emissions (Dalal *et al.* 2016; Jabbar *et al.* 2022).

This research article is aimed for developing solar-powered backpacks mainly for comfortable traveling or campaign applications. Furthermore, we have changed the conventional grass cutter machine to a solar grass cutter as it can be more easily manually operated with minimal effort by using solar energy (Bhalodi *et al.* 2020). Another addition of small-scale solar appliances in this paper is a solar farm hat which is produced to make the farmer's life more comfortable during their work. The farm hat is changed into a solar farm hat by integrating small size solar panel on the top of the hat and also adding LED light and fan which is operated by

electricity generated from solar panels. Solar-powered devices are designed and developed in such a way that one can easily operate them using solar energy.

Selection of solar panel

Solar energy is now a most promising, sustainable, and clean source of power. In the twenty-first century, the demand for solar PV technology is rapidly spreading and becomes the most competitive option for electricity generation in a growing number of countries (Haque *et al.* 2022). Generally, a solar cell generates electricity when sunlight hits upon it. The first-generation solar cell is a p-n junction semiconductor device that is produced by doping with n-type material on one side of the intrinsic semiconductor and p-type material on the other side of the silicon wafer. When a photon of sunlight falls upon the p-n junction of the solar cell, free electrons and holes are generated. After that, these free electrons are induced by the electric field building up near the p-n junction and then flow out of the solar cell through the connecting wire (Usikalu *et al.* 2019). Thus electricity is generated while electrons are flowing through the circuit. A certain number of solar cells are assembled in a framework called solar modules or solar panels which are designed to produce electricity at a certain voltage. Nowadays there are different types of silicon solar panels available on the market. Solar panel selection is an important task due to its cost and efficiency. There are three major types of solar cells available in the market such as monocrystalline, polycrystalline and another is 2nd generation thin film solar cells. Among them, monocrystalline solar cells have the highest level of efficiency at 15 to 22% due to the presence of the maximum amount of silicon per unit area (Sawle and Thirunavukkarasu, 2021). As a result, they require less space and give a longer lifetime warranty than the other two types of solar cells. Due to higher efficiency and longer lifetime, monocrystalline solar cells are the most expensive solar cell in the market (Taverne *et al.* 2018). On the other hand, polycrystalline solar cells require less amount of silicon per unit area, as molten silicon is poured into square molds during manufacturing. In the case of thin film solar cells, they also require less and cheaper materials during manufacturing which makes them more flexible and lightweight (Su *et al.* 2010; Rathore *et al.* 2021). As the small-scale solar appliances have less amount of allowable space and also need flexibility in some cases, alongside the monocrystalline solar panels, thin film solar panels are also selected for hiring better performances in this project.

Results and discussion

Solar backpack

The solar-powered backpack comprises a backpack, solar panel, charging circuit, rechargeable battery and a USB port for charging the devices as shown in Fig. 1. Any kind of portable device can be charged using a solar backpack via USB port. The battery is charged in the daytime and it allows using the devices in day and night time also. The top part of the backpack was a plane (8"X12"), and hence the solar panel

regulator that regulates the 17V solar panel voltage down to 6V. Later, this voltage charges up the 6V 4.5 Ah lead acid batteries. In the charging circuit, diode D2 impedes to flow of the discharging current from the battery to the solar panel. At first, transistor T1 and Zener diode ZD1 are normally off and the battery becomes charging. When the terminal voltage of the battery rises above 6.8 volts, Zener conducts and provides the base current to T1. Subsequently, current flows through the transistor T1 and it then activates the grounding of L7806 IC to cut off the charging cycle of the battery. It can also charge the mobile directly by USB cable. The Zener diode,

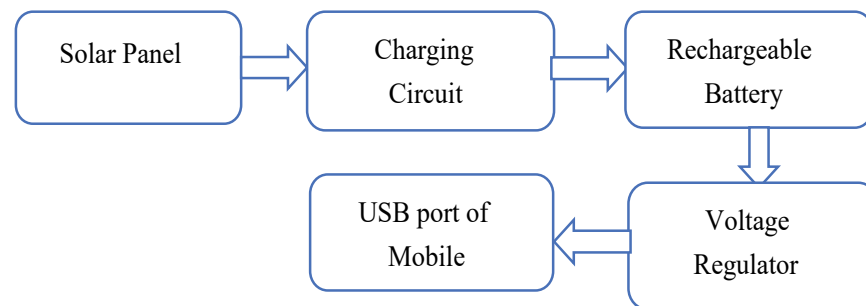

Fig. 1. Block diagram of solar powered backpack charger

Table I. Solar panel specifications for charger backpack

Specification	Value
Maximum power	5W
Maximum power voltage (V_{mp})	17 V
Maximum power current (I_{mp})	0.30 A
Open circuit voltage (V_{oc})	21.5 V
Short circuit current (I_{sc})	0.31 A
Cell type	Monocrystalline/ Thin film

could be set up easily. The specification of the solar panel used for this work is given below in Table I.

Operation principle of solar powered backpack charger

A 5W solar panel was set up on the top side of the backpack of the solar-powered charger. This solar panel is then connected to a small PCB (printed circuit board) which was designed for storing charge into a battery placed inside of the backpack. Fig. 2 shows the charging circuit diagram where a 17V solar panel produces electricity when it comes to the presence of sunlight. A Diode D1 (IN4007) is connected in series with the panel to prevent the backflow of current supplied from it. The circuit consists of an IC L7806 voltage

ZD2 of the charging circuit further regulates the voltage down to 5.6 volts and directly transfers voltage to the USB cable of the mobile phone for charging purpose.

Testing

After designing the charging circuit diagram of the solar charger backpack, it was tested first in the laboratory. Initially, the output voltage of the mobile charging port and also the battery voltage level were tested according to the input voltage using a power supply to ensure the workability of the charging circuit. Fig. 3(a) shows the charging circuit tested on a breadboard in the laboratory and in Fig. 3(b) the circuit was tested on a sunny day using a solar panel as input. During testing the charging circuit in the laboratory, we got two

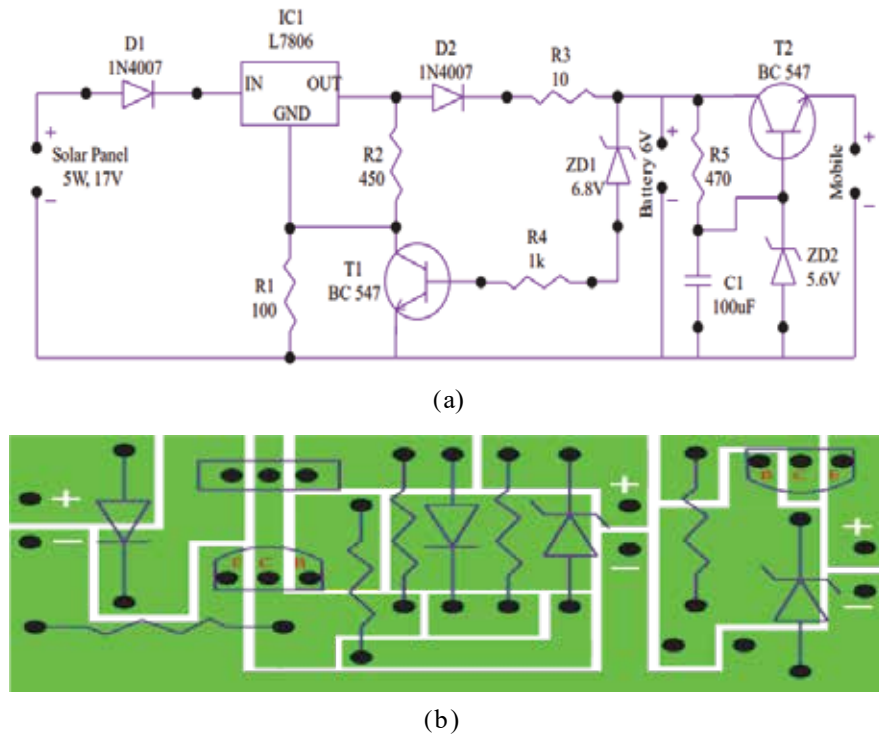

Fig. 2. (a) Charging circuit diagram and (b) PCB layout of solar backpack charger

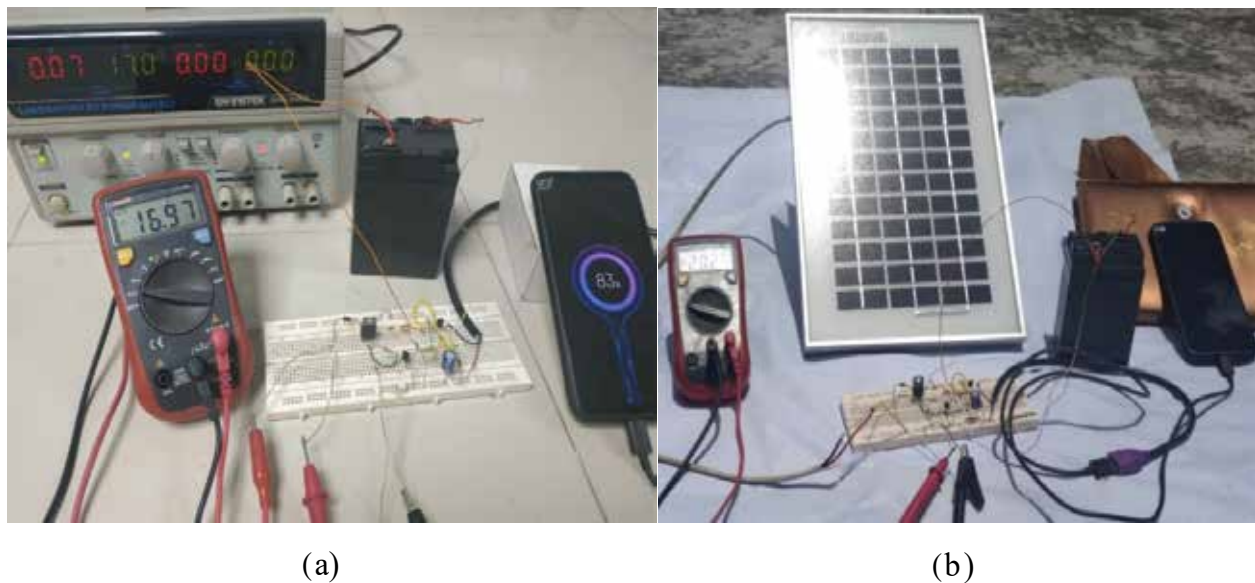

Fig. 3. (a) Test set up of the charging circuit in laboratory and (b) Outdoor test setup of the mobile charger using solar panel

graphs which are shown in Fig. 4 by monitoring the battery voltage and load voltage using a multimeter. It can be seen from figure that the output voltage of the battery was almost stable and didn't so much fluctuate according to the input

voltage of the solar panel. At first, battery voltage was linearly increased to above 6 volts and then slowly stable at 6 volts when solar panel input voltage was varied from 10 to 20 volts. Furthermore, the mobile phone was also charging

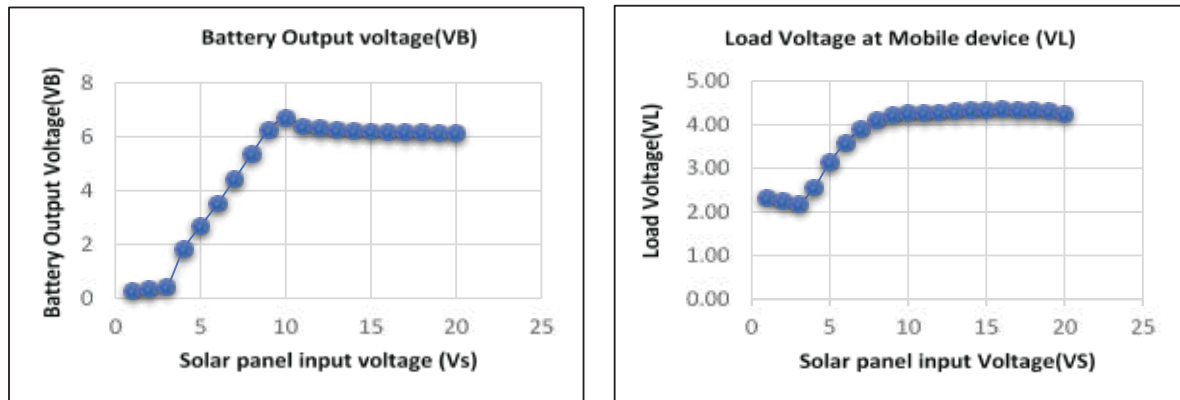
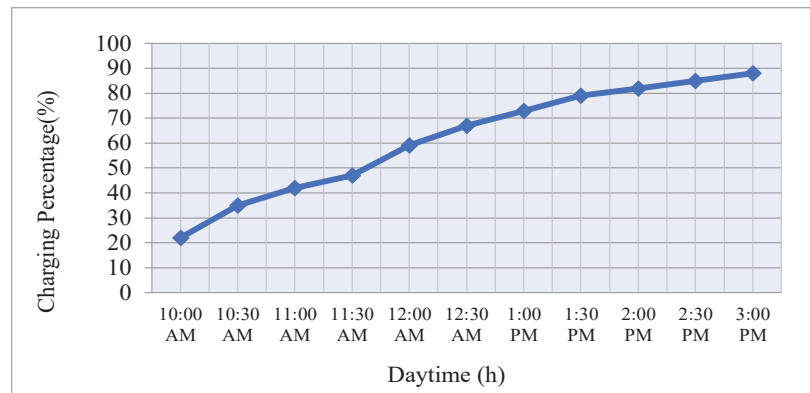
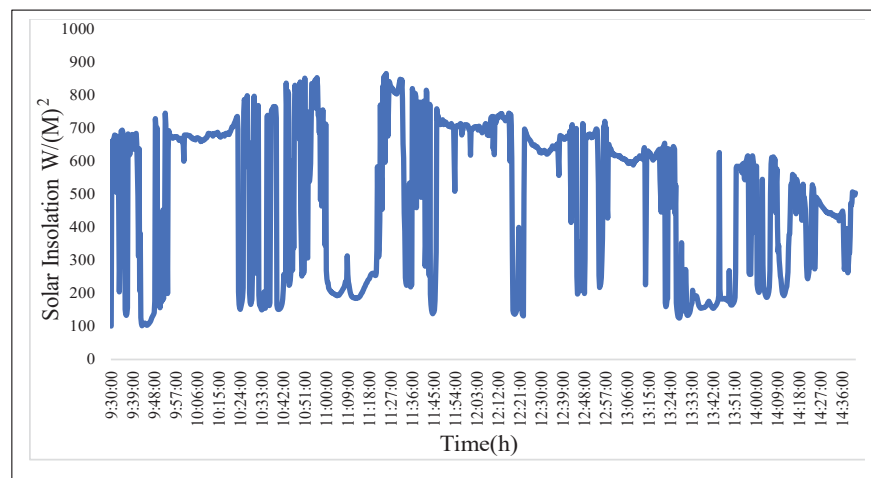

Fig. 4. (a) Battery output voltage test and (b) Charging voltage test at mobile device



(a)



(b)

Fig. 5. (a) Charging percentage test of mobile phones from 10:00 am to 3:00 pm (b) Solar insolation graph during the day

almost at a fixed voltage which was nearly constant at 4 volts when the solar input voltage changed from near about 5 to 20 volts. It showed favorable performances by charging a mobile phone of 4000 mAh capacity. After being successful-

ly tested in the laboratory, the whole charging unit was then put into the sunlight and connected with the solar panel for proving the performance. Fig. 5 (a) shows the charging percentage of mobile phone that was taken on a sunny day in

July month of the year from 10:00 am to 3:00 pm and Fig.5 (b) shows the solar radiation that falls on the location during the experimental period. At first, the charge of the mobile phone was 22% when we placed the solar panel in the sunlight. The charging unit drew electricity from the panel and started to charge the mobile phone at 10:00 am. The charging percentage of the mobile was recorded for every half an hour interval and overall 88% charge was found in about 5 hours. We also monitored the voltage coming from the solar panel via the voltage multimeter. From the charging graph, we see that the mobile charger takes a long time to charge the mobile phone due to two reasons. First, we have



(a)

Solar grass cutter

Addressing the environmental pollution issues, the conventional grass cutter is modified by replacing fossil fuel energy with solar energy sources. This modified solar-powered grass cutter (shown in Fig. 7) comprises a solar panel, direct current (DC) motor, a solar charge controller, two 6V rechargeable batteries which are connected in series, a stainless-steel linear blade and a control switch to control the motor speed. Grass cutting also known as mowing is performed by the DC motor that supplies the necessary speed required to drive the linear blade. This blade is further incorporated with the shaft of the DC motor. A



(b)

Fig. 6. (a) Solar backpack using silicon solar panel (b) Solar backpack using thin film solar panel

used a linear-type voltage regulator whose efficiency is lower than a switching-type regulator. Generally, the efficiency rates of the switching type regulator can be greater than 90%. The other reason is that the sky was found sometimes cloudy on that day. This is evident from the solar insolation graph of Fig. 5(b). As the photon current decreases with the decrease of solar radiation- which in turn reduces the power output, and hence the efficiency of the solar module (Sharma and Goyal, 2021). So, the frequent change in current due to insolation variation at the output makes the mobile charging time longer. Therefore, we recommend using a switching regulator than a linear voltage regulator for faster charging speed of mobile chargers. The final product of the solar charging backpack is shown in Fig. 6 where four thin film solar panels with the same efficiency and specification as monocrystalline solar panels are used for easy carrying backpack on the outside.

switch is attached to the handle of the solar-powered grass cutter that completes the circuit connection and permits the current to flow through the motor. Subsequently, the motor drives the blade which is connected to it. The blade will get enough kinetic energy to cut the grass while increasing speed. This grass cutter uses 12V batteries to power the electric motor when sunlight is not available. It can also directly deliver power to the motor using sunlight through solar panels.

Design description

This grass cutter is mainly designed to use solar energy to drive the cutting blades fitted to the shaft of the motor. The design of this solar-powered grass cutter is simple and the materials that are selected to fabricate the machine are described in Table II.



Fig. 7. Different components of solar grass cutter used in this project

Table II. Material selection for solar grass cutter

Material Selection	Description
Solar module	Thin film solar panel of 18V and 20W with open circuit voltage 21.6V and short circuit current 1.22A
Solar charge controller (Model-RTD1230)	Pulse with modulation regulator with battery voltage 12V and current 30A
Battery	Two 6V 5.5AH Lead acid
Motor	DC motors of 12V and 10W

The whole structure is supported in a framework of metal sheets. Two front and two rear wheels are incorporated into the design to make the machine more comfortable for a user during cutting grass. The cutting blades are covered with metal sheets so as not to let the cut grasses spread away and

it also makes safety for the user. The overall dimension of the machine will be depended on the dimension of the solar panel that is placed on the top surface of the machine. A 48×35cm monocrystalline solar panel is used to generate electricity by receiving solar radiation directly from the sun. Two 6 Volt batteries are used to store the electricity by using a solar charge controller. The charge controller is positioned between the solar panel, battery, and motor load where they are all connected in series. A complete setup diagram is placed in Fig. 8. The main function of the charge controller is to maintain the voltage level of the battery. When the battery voltage is low, the charge controller connects the battery to the panel for charging and also disconnects the panel from the batteries when they are fully charged. Similarly, the charge controller also disconnects the battery from the load to avoid over-discharging of them. This function of the charge controller is done by a switch.

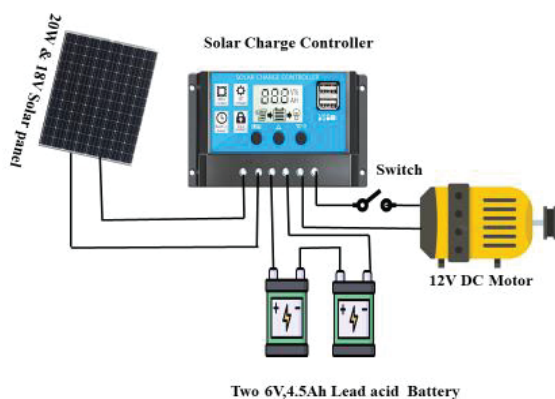

Fig. 8. A complete setup for the designed solar power grass cutter

Design calculation

In the case of fabricating different parts of the solar-powered grass cutter machine, a design calculation is very much

important. These calculations were carried out by the equations described in the references (Okafor, 2013; Akene, 2020; Ismail *et al.* 2019). First of all, we need to consider the power consumed by the cutting blade. The blade power can be calculated by multiplying the torque developed by the cutter and angular velocity using Eq. (1).

$$P = \tau\omega \tag{1}$$

here, P represents the power developed by the blade and represents the torque and angular velocity of the cutter respectively.

But angular velocity, $\omega = \frac{2\pi N}{60}$ (2);

here, N is the speed of the motor delivered to the blade.

Now, the torque developed by the blade can be calculated using Eq. (3), where W represents the weight of the blade and R represents the radius of the blade.

$$\tau = WR \tag{3}$$

Thus, the calculation of blade power is important for the selection of motor power because the power of the motor which is to be selected must be higher than the blade power (Akene, 2020; Deepak *et al.* 2018). Now, the power supplied by the solar panel as input power can be calculated from Eq. (4).

$$P=VI \tag{4}$$

Where P is the power of the solar panel and V and I represent the voltage and current respectively. By implementing Eq. (4), it is found that the maximum current supplied by solar panels is 1.11A.

During the operation period, Charge Controller provides required electrical energy to the DC motor to drive the blade. So, the maximum current consumption of the DC motor can be also calculated from Eq.4. We found maximum current consumption of the DC motor is 833mA which is quiet enough to drive the blade during the operation period.

A battery is an important part of the grass cutter because it stored solar energy and delivered it to load when sunlight intensity is very low or even on a cloudy day. The charging time of the battery is usually dependent on the charging current and charging capacity. Hence. The battery charging time can be calculated from Eq. (5).

$$\text{Battery charging time} = \frac{\text{Battery capacity}}{\text{Charging current}} \tag{5}$$

Here, we used two 6V 4.5Ah batteries, so each battery takes 4.05 hours to be fully recharged by using current (1.11 A) coming from the solar panel. The charging of the battery is so much affected by the intensity of the sunlight. High sunlight intensity may take less time to charge the battery. As the grass cutter can operate directly from solar power during the day time so the battery lifetime also increases. Moreover, all the parts of the machine have been fully fabricated and assembled as depicted in Fig.7.

Solar farm hat

The hat used by farmers in Bangladesh is locally made and called Mathal in Bengali. This is available in the market. In this work, it is used not only for shading but also for cooling the face, charging electronic devices such as cellphones, and lighting also. The top part of the farm hat should be plain as the solar panel could be set up easily.

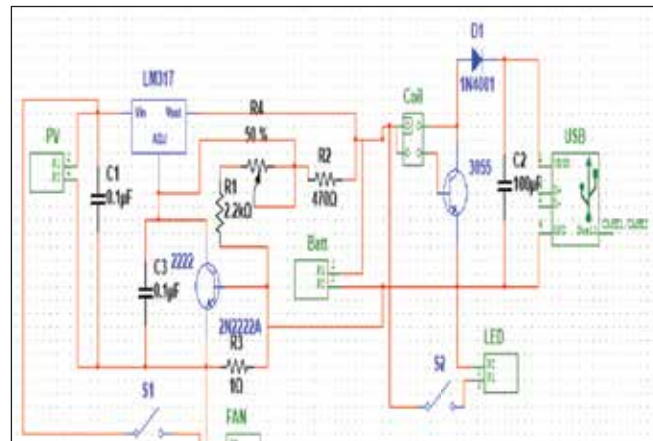

Fig. 9. Charging circuit diagram of solar farm hat

Circuit design and implementation

Six small-size solar panels, a 1.92W DC fan, and four LEDs were settled at the top of the hat. A small PCB (printed circuit board) was designed as shown in Fig. 9(b) and is connected to the solar panel of the farm hat. The circuit as shown in Fig. 9(a) uses six 6V/1W solar panels. These solar panels convert solar power into electricity when sunlight falls upon them. The circuit uses a variable voltage regulator IC LM317 that regulates output voltage coming from the solar panel and charges the 3.7volt 2200 mAh rechargeable li-ion battery which can then charge the cellphone via connecting USB cable. The fan is directly connected to the 6W solar panel so that it will be on only when the farm hat is in direct contact with the sunlight. On the other hand, LED lights are connect-

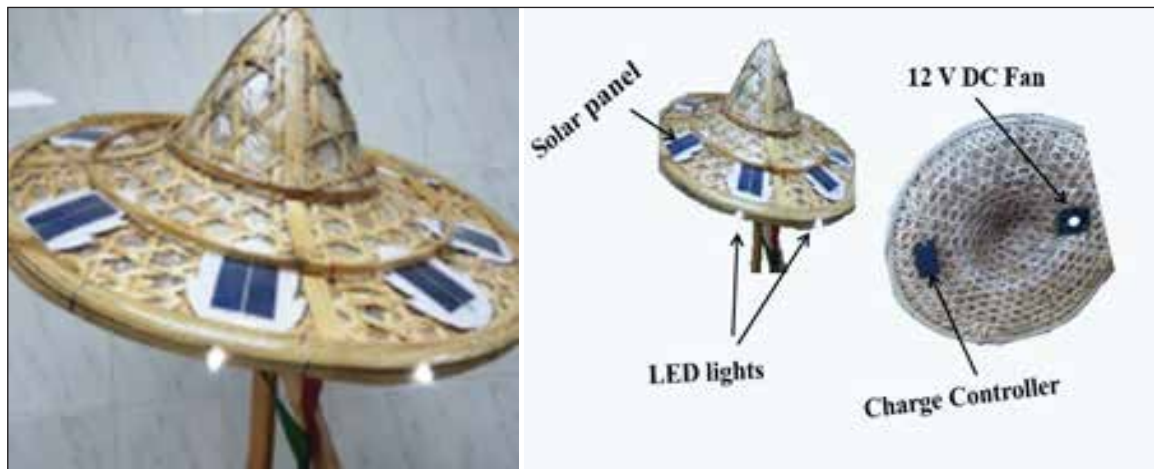

Fig. 10. A complete setup of solar farm hat

ed to the circuit in such a way that they can harness electricity directly through the solar panel and also from the battery in the absence of sunlight. By using a switch, a farmer can control the lights and fan according to his requirements.

For the implementation of the solar farm hat (Fig. 10), at first six small sizes solar panels were tested in the laboratory and also under the sunlight. Then they were placed on a cap made with bamboo which is locally called Mathal in Bangladesh. A complete setup of the solar farm hat is shown in Fig.10 along with a physical diagram of the charging circuit unit. One can easily produce this type of farm hat using the following materials listed in Table III. Farm hat shows excellent performance during the day time and also night time. The fan draws current directly from the solar panel during day time and also from the battery when the intensity of sunlight is very low such as on a cloudy day. From Eq. 5, it can be calculated that around

Table III. List of required materials to design a solar farm hat

Materials Specifications	Quantity
Solar Panel (1W and 6V)	06
IC (3055), IC(LM317) & Diode(1N4001)	01
Register (2.2k Ω , 1 Ω , 470 Ω , 1K Ω variable)	01
0.1 μ F Capacitor	02
100 μ F 16V Capacitor	01
USB Connector, Coil & Round Core	01
PCB board (3.5 cm x 7 cm)	01
Micro Switch	02
18675 Li-ion Battery (3.7V)	01
DC fan	01
Ultra bright LEDs (5mm & 3volt)	04
Farm Hat & Box (4cm x 8cm x 3cm)	01

1.8 hours need to recharge the battery using current coming from the solar panel. Here, we also used linear voltage regulator IC LM317 in the charging circuit and practically we found charging the battery of the farm hat which follows the result almost same as like as solar backpack.

Conclusion

Three different types of solar-powered devices have been designed and developed to make people's life easy and comfortable. First of all, for the solar-powered backpack, the overall circuit design and implementation have been successfully done to charge the mobile phone at an efficient rating. In this case, we have used monocrystalline as well as thin film solar cells having a maximum power capacity of 5W and a maximum voltage of 17V. The mobile phone having a battery capacity of 4000 mAh was successfully charged from 22% to 88% within 5 hours under direct sunlight in a cloudy weather. The design and calculation of solar grass cutter have been described. It can be an excellent machine for mowing grass utilizing solar energy and saving fuel. Finally, the farm hat has also been successfully designed and implemented using six small-sized 1W and 6V monocrystalline solar panels. These solar panels are connected in series to provide enough power to drive the 12V DC fan and 4 LED lights and charger efficiently. Farmers get comfort by cooling their faces, charge their mobile phone and also getting lighting by using our developed solar farm hat. In conclusion, these three solar-powered devices can keep role to utilize solar energy in different ways.

References

Adejuyigbe SB, Bolaji BO, Olanipekun MU and Adu MR (2013), Development of a solar photovoltaic power system to generate electricity for office appliances,

- Engineering Journal*. **17**(1): 30-39. DOI:10.4186/ej.2013.17.1.29
- Akene A (2020), Design and Fabrication of a Solar Powered Lawnmower with Adjustable Wheels, *International Journal of Engineering Research & Technology (IJERT)*. **9**(5): 390-396.
- Athina D, Kumar DK, Kalyani RB and Vittal K (2021), Solar Grass Cutter Using Embedded Platform An Experimental Validation, *IOP Conference Series: Materials Science and Engineering*. **1057**(1): 12-86.
- BAŞOĞLU ME and ÜSTEK SM (2021), Prototype development of a solar-powered backpack for camping applications, *Gazi University Journal of Science Part C: Design and Technology*. **9**(4): 589-596.
- Bhalodi T, Bhujbal N, Doshi K, Goregaonkar R and Jagtap S (2020), Environmental Friendly Solar Grass Cutter, *International Journal of Research in Engineering, Science and Management*. **3**(7): 177-180.
- Dalal MSS, Sonune MVS, Gawande MDB, Sharad M, Shere B and Wagh MSA (2016), Manufacturing of solar grass cutter **In**: National Conference “CONVERGENCE 2016”.
- Deepak AR, Kunwar K, Daneesh E, Kadayat R and Punith CN (2018), Design and Fabrication of Solar Grass Cutter, *International Journal of Latest Engineering Research and Applications (IJLERA)*. **3**(5): 8-12.
- Haque AKE, Mukhopadhyay P, Nepal M and Shammin MR (2022), Climate Change and Community Resilience: Insights from South Asia, *Springer Nature Singapore*. <https://doi.org/10.1007/978-981-16-0680-9>
- Ismail FB, Al-Muhsen NF, Fazreen AF and Zukipli A (2019), Design and development of smart solar grass cutter, *International Journal of Engineering and Advanced Technology* **9**(2): 4137-4141.
- Jabbar MW, Noman M, Muneer A, Abbas A and Mazhar A (2022), Solar powered grass cutter for domestic utilization, *Engineering Proceedings* **12**(1): 105. <https://doi.org/10.3390/engproc2021012105>
- Mudda M, VishwaTeja SK and Kumar P (2018), Automatic solar grass cutter, *International Journal for Research in Applied Science and Engineering Technology* **6**(4): 1148-1151.
- Mudi S (2020), Design and Construction of a Portable Solar Mobile Charger, *World Academics Journal of Engineering Science* **7**(1): 40-44.
- Okafor B (2013), Simple design of self-powered lawn mower, *International Journal of Engineering and Technology* **3**(10): 933-938.
- Rathore N, Panwar NL, Yettou F and Gama A (2021), A comprehensive review of different types of solar photovoltaic cells and their applications, *International Journal of Ambient Energy* **42**(10): 1200-1217.
- Sawle Y and Thirunavukkarasu M (2021), Techno-economic comparative assessment of an off-grid hybrid renewable energy system for electrification of remote area, Design, Analysis, and Applications of Renewable Energy Systems, Academic Press, pp 199-247. <https://doi.org/10.1016/B978-0-12-824555-2.00027-7>
- Shaikh MRS, Waghmare SB, Labade SS, Fuke PV and Tekale A (2017), A review paper on electricity generation from solar energy, *International Journal for Research in Applied Science & Engineering Technology (IJRASET)* **5**(IX): 1884-1889.
- Sharma P and Goyal P (2021), Analysing the effects of solar insolation and temperature on PV cell characteristics, *Materials Today: Proceedings* **45**(6): 5539-5543. DOI: 10.1016/j.matpr.2021.02.301
- Su Q, Lai J, Zhang G, Feng S and Shi W (2010), Flexible thin film solar cells using in the car, *World Electric Vehicle Journal* **4**(4): 793-797.
- Tabassum S, Bashar MS, Islam MS, Sharmin A, Debnath SC, Parveen S and Khanom SAA (2019), Design and development of solar dryer for food preservation, *Bangladesh Journal of Scientific and Industrial Research* **54**(2): 155-160.
- Taverne J, Muhammad-Sukki F, Ayub AS, Sellami N, Abu-Bakar SH, Bani NA, Mas'ud AA and Iyi D (2018), Design of solar powered charging backpack, *International journal of power electronics and drive systems* **9**(2): 848-858. <http://doi.org/10.11591/ij-peds.v9.i2.pp848-858>
- Usikalu MR, Adebesein E and Obafemi LN (2019), Design and construction of backpack mobile charger, *ARPN Journal of Engineering and Applied Sciences* **14**(21): 3743-3746.