



BCSIR

Available online at www.banglajol.info

Bangladesh J. Sci. Ind. Res. 46(4), 457-464, 2011

**BANGLADESH JOURNAL
OF SCIENTIFIC AND
INDUSTRIAL RESEARCH**

E-mail: bjgir07@gmail.com

Digital Simulation of Pmblcdc Motor Drive with Power Factor Correction

T. V. Narmadha^a and T. Thyagarajan^{b*}

^aResearch Scholar and ^bDept. of Instrumentation Engg MIT Campus, Anna University, Chennai, India

Abstract

In this paper, performance of voltage source inverter (VSI) fed Permanent Magnet Brushless DC Motor (PMBLDCM) with Power Factor Correction (PFC) is discussed. A power factor correction converter is suggested at the input to correct the power factor on the input side. The conventional circuit is improved by introducing double boost converter at the input side. The Pulse Width Modulation (PWM) inverter fed Permanent Magnet Brushless DC motor system with L-filter, T-filter and double boost converter are simulated and the results are presented. The performance of PMBLDCM operating with the above mentioned converters is studied. By digital simulation, the characteristics of the PMBLDCM system are investigated. FFT analysis for various converters is presented. The simulation results indicate improved performance.

Key words : VSI, Double boost converter, PMBLDC, Harmonic reduction, PWM, PFC, Sim power systems

Introduction

Permanent Magnet Synchronous Motor (PMSM) with sinusoidal shape back-EMF and brushless DC (BLDC) motor with trapezoidal shape back-EMF drives have been extensively used in many applications, ranging from servo to traction drives due to several distinct advantages such as high power density, high efficiency, large torque to inertia ratio, and better controllability (Hao and Toliyat 2003). Brushless DC motor (BLDC) fed by two-phase conduction scheme has higher power/weight, torque/current ratios and it is less expensive due to the concentrated windings which shorten the end windings compared to three-phase permanent magnet synchronous motor (PMSM) (Krishnan 2002; Pillay and Krishnan 1991 and Uzuka *et al* 1985). The most popular way to control BLDC motors is by PWM current control in which a two-phase feeding scheme is considered with variety of PWM modes. In general, AC motor drives have very poor power factor due to the harmonics in the line current. As compared to conventional analog controllers, digital regulators offer several advantages such as possibility of implementing nonlinear and reduction of the number of control components, high reliability, low sensitivity to component aging, better performance than that in analog implementation with the same cost, reduced susceptibility to environmental variations such as thermal drifts, and negligible offsets. Digital control PFC implementations have been investigated by many researchers (Buso *et al* 1998; Fu 2001 and Zhou *et al* 2001). Majority of the work has been done on the

implementation of the analog PFC techniques in the digital platform. Power factor correction of DTC PMBLDCM system is presented by (Salih *et al* 2007). Single chip integration for motor drive converters with powerfactor capability is given by Consoli (Alofio 2004). Energy recovery stage is used for active power control operation. There is very little work in the literature to implement the PFC methods. The above literature does not deal with double boost converter-VSI fed BLDC motor. In the present work, double boost converter is proposed at the input side to improve the power factor.

PMBLDC motor drive systems

Permanent Magnet Brushless motor drive with various input filters is considered. VSI fed PMBLDC motor with L-filter and T-filter are discussed in this section.

VSI fed PMBLDC motor

Fig. 1 shows the schematic diagram of the VSI fed BLDC motor. An uncontrolled diode rectifier is used to convert the single phase AC voltage into a constant DC link voltage. The output of the rectifier is fed to the PWM inverter fed BLDC motor. The MATLAB simulation of the VSI fed BLDC motor is carried out and the simulation results are presented in section-3. The phase angle between voltage and current is very large. L-filter/ T-Filter may be used to reduce the phase angle so that the power factor can be improved.

*Corresponding author. E-mail: thyagu_vel@yahoo.co.in

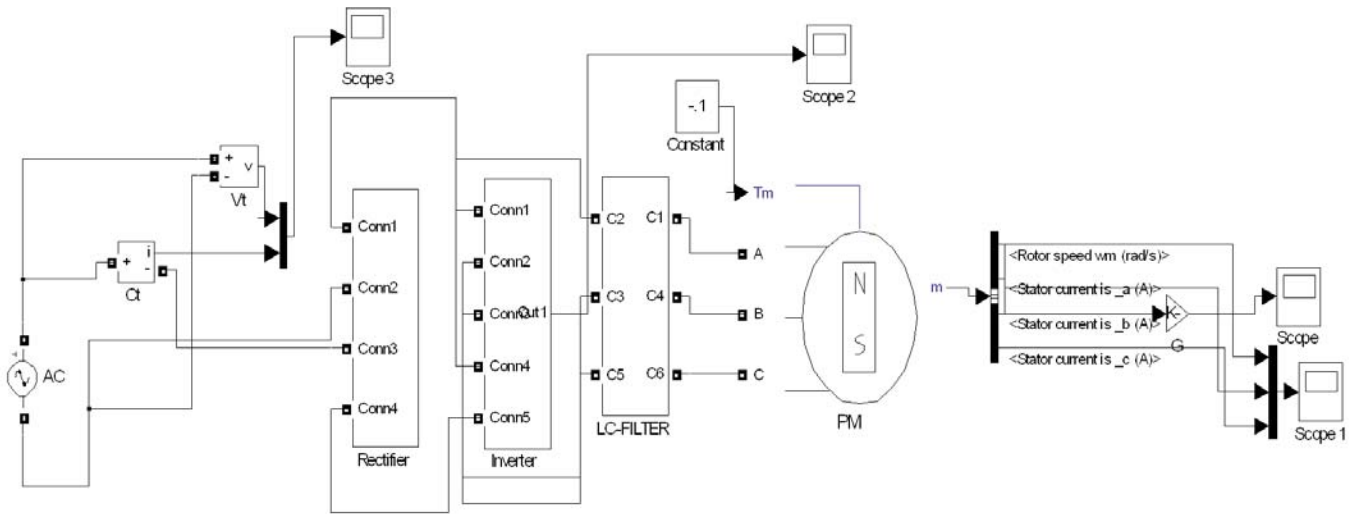

Fig. 1: VSI fed BLDC motor

VSI fed BLDC motor with L- filter

Inductors and capacitors are used in conjunction with the diode rectifier bridge to improve the waveform of the current drawn from the utility grid. The simplest approach is to add an inductor on the AC side of the bridge rectifier as

shown in Fig. 2. The phase angle between voltage and current can be reduced by using L-filter.

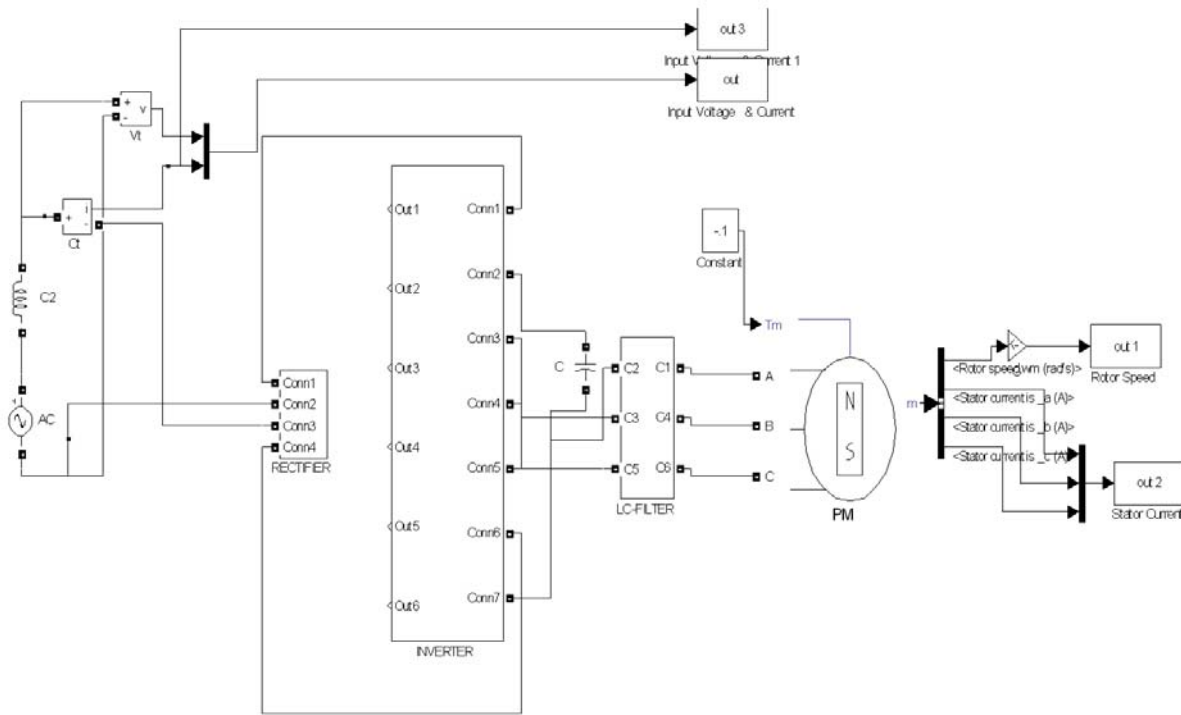

Fig. 2: VSI fed BLDC motor with L- filter

VSI fed BLDC Motor with T-filter

It is possible to further improve the input power factor by using a T-filter on the AC side. The AC line current can also be smoothed by using filters in the line just before the power electronic converter system. Inductors L_1 and L_2 basically increase source side inductance. They reduce higher order harmonics in the current. They also reduce output

of the rectifiers can be made sinusoidal and in phase with the input voltage, thereby having an input power factor of approximately unity. A unity power factor circuit that combines a double boost converter and 3- phase inverter circuit fed BLDC motor drive is shown in Fig. 4a. Double Boost Converter circuit is shown in Fig. 4b.

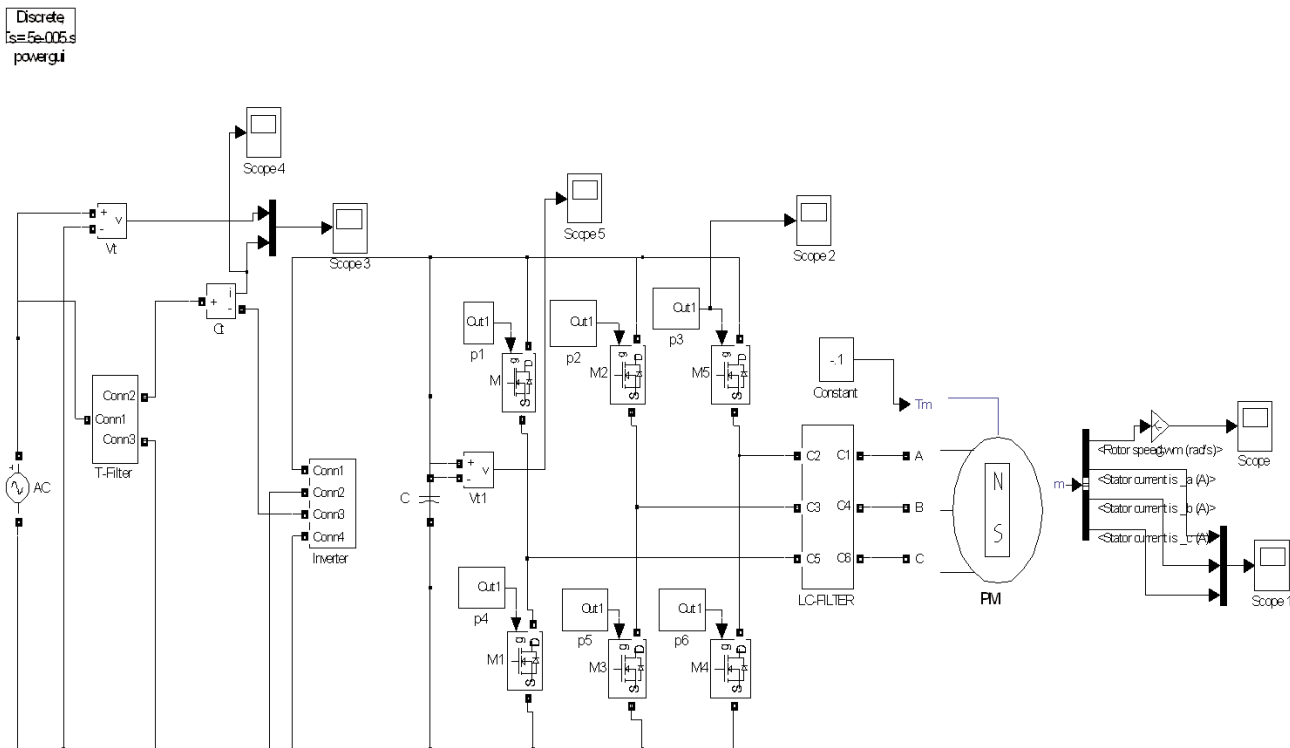

Fig. 3: VSI fed BLDC motor with T-filter

Double Boost converter and 3- phase inverter fed BLDC motor

It is possible to further improve the powerfactor using Double Boost Converter. Diode rectifiers are the most commonly used circuits for applications where the input supply is AC. The power factor of diode rectifiers with a resistive load can be as high as 0.9 and it is lesser with a reactive load. With the aid of modern control technique, the input current voltage ripple and current stresses on the rectifier diodes. The capacitor suppresses the high frequency harmonics and transients from being coupled to and from the source. The phase angle can be further reduced by using T-filter. The T-filter is designed such that X_L is greater than X_C .

PWM Inverter fed brushless DC motor drive

The PWM inverter configuration is also termed as six step bridge inverter. MOSFETs are used as switching devices. The double boost converter is connected to three-phase Brushless DC motor through a three-phase bridge inverter with a suitable control circuitry which changes the switching frequency of the Inverter. For speed control of motor, the output frequency of Inverter must be varied. The applied voltage to the motor must also be varied in linear proportion to the supply frequency to maintain the flux constant.

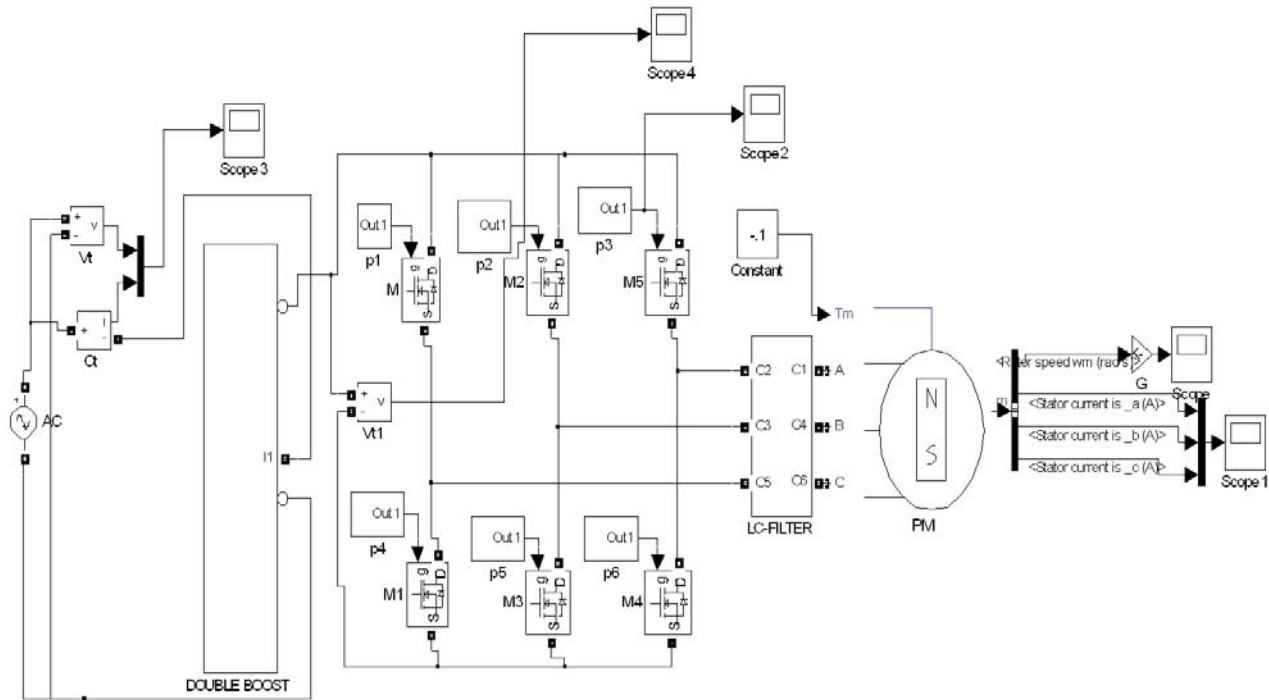

Fig. 4a: Double boost converter fed BLDC motor

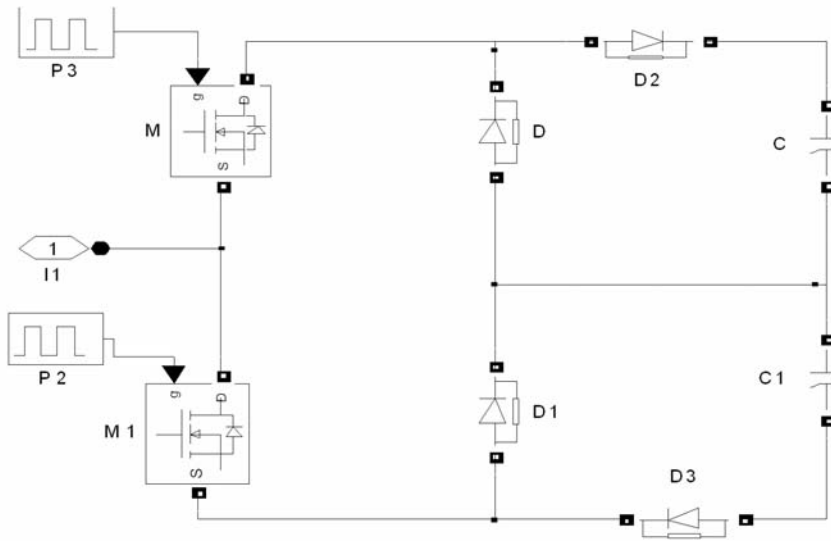

Fig. 4b: Double boost converter circuit

Simulation Results

With the help of designed circuit parameters, the MATLAB simulation of the above circuits are performed and the results are given here.

VSI fed BLDC motor

The Simulation results of input voltage and input current of VSI fed BLDC motor are shown in Fig. 5a. It is seen that the

phase difference between input voltage and input current is large. Hence the power factor is poor. The rotor speed characteristic of VSI fed BLDC motor is shown in Fig. 5b. The three phase output current of VSI fed BLDC motor is shown in Fig. 5c and it is nearly sinusoidal. The Frequency Spectrum of VSI fed BLDC motor is shown in Fig. 5d. The total harmonic distortion is 20.28 % when the motor is operated at 50 Hz frequency with constant torque load.

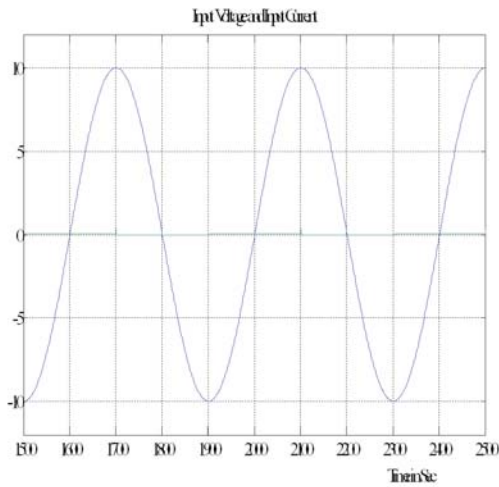

Fig. 5a: Input voltage and current

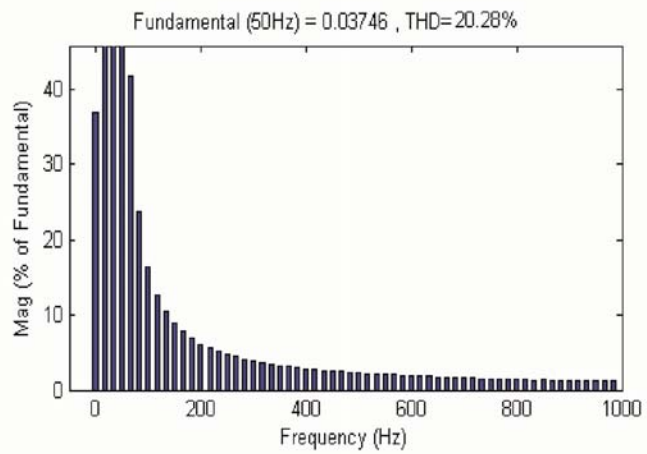

Fig. 5d: Frequency spectrum of input current

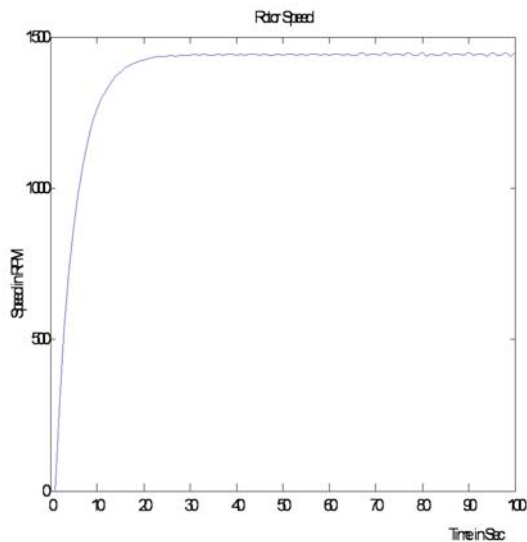

Fig. 5b: Rotor speed characteristic

VSI fed BLDC motor with input L-Filter

The input voltage and current of VSI fed BLDC motor with input L-filter are shown in Figure 6a. The phase difference between input voltage and input current is comparatively less than that of VSI fed BLDC motor. Hence with L-filter, the power factor is improved. Fig 6b. shows the rotor speed of VSI fed BLDC motor with input L-filter. The simulated result shows that rotor settles at rated speed . Fig 6c indicates that the output current waveform is sinusoidal. Fig 6d. shows the Frequency Spectrum of VSI with input L-filter and the corresponding total harmonic distortion is 12.39%. Thus THD is reduced by adding inductor filter.

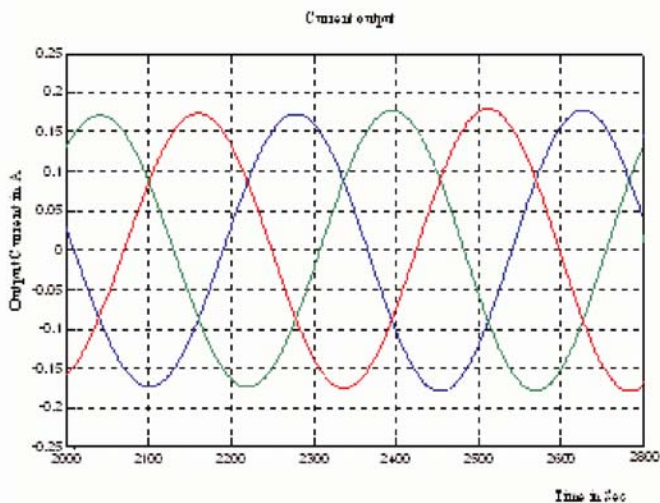

Fig. 5c: Three phase current waveform

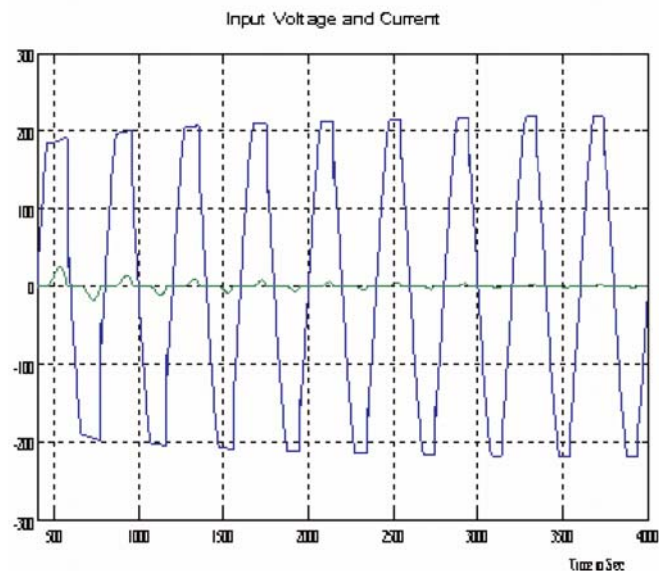

Fig. 6a: Input voltage and current waveforms

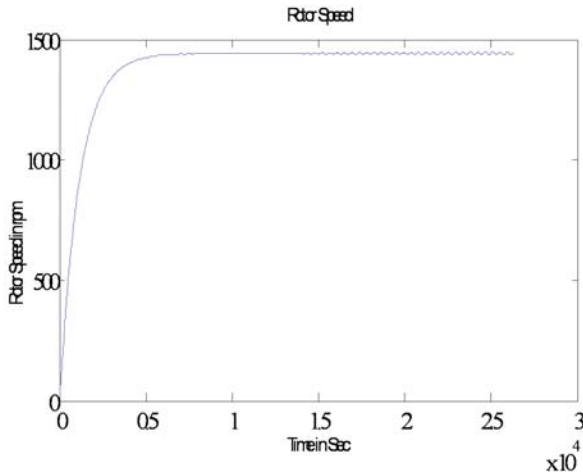

Fig. 6b: Rotor speed characteristic

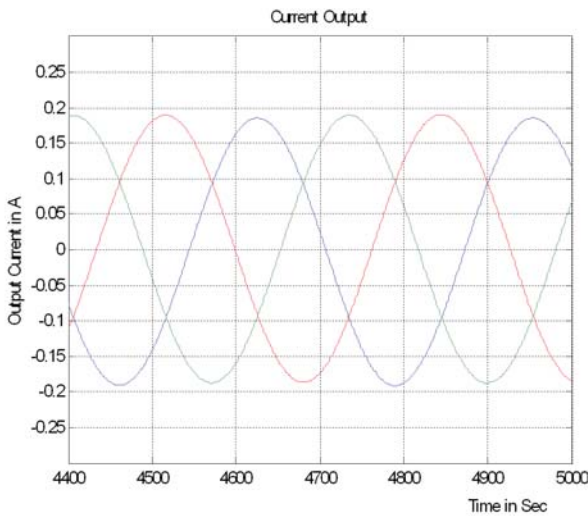

Fig. 6c : Output current waveform

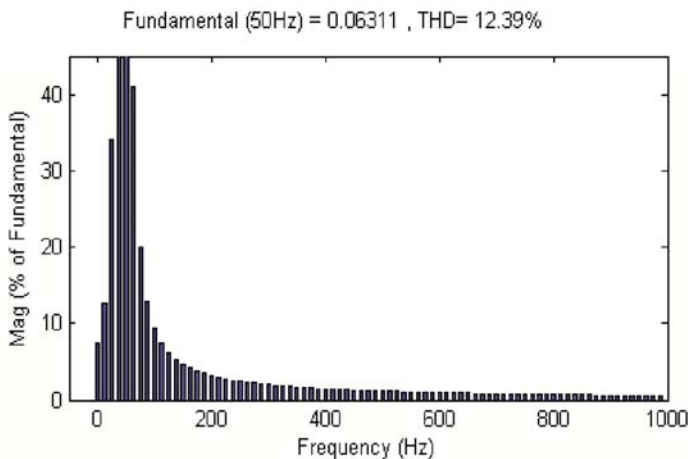

Fig. 6d: Frequency spectrum of input current

VSI fed BLDC motor with input T Filter

The input current waveform of VSI fed BLDC motor with input T filter is shown in Fig. 7a. The input voltage and current waveforms of VSI with input T filter fed BLDC motor is shown in Fig. 7b. It is seen that phase difference between input voltage and input current is reduced. Hence the power factor is improved and it is higher than that of L- filter fed BLDC motor. The rotor speed of VSI fed BLDC motor with input T-filter is shown in Fig. 7c. The simulated result shows that the rotor reaches the rated speed in 0.5 seconds. Fig 7d. shows that the output current waveform is sinusoidal. Fig 7e. shows the Frequency Spectrum of VSI with input T-filter. The total harmonic distortion reduces to 11.59% by using T- filter at the input.

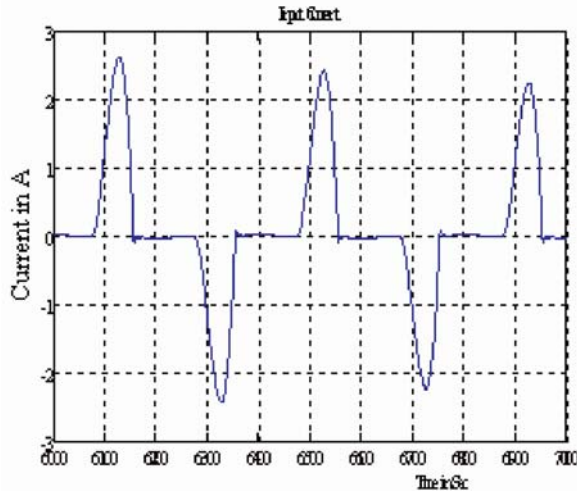

Fig. 7a: Input current waveform

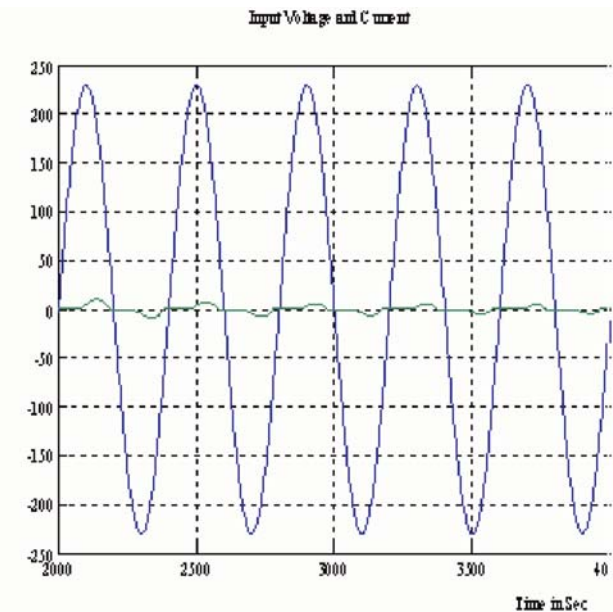

Fig. 7b: Input voltage and current waveforms

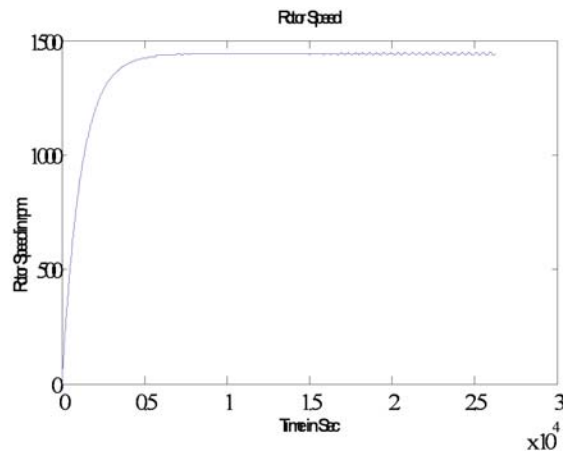

Fig. 7c: Rotor speed characteristic

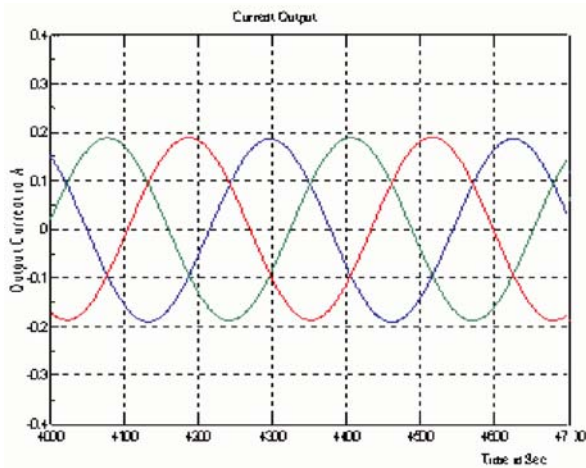

Fig. 7d: Stator current waveform

Fundamental (50Hz) = 0.05723 , THD= 11.59%

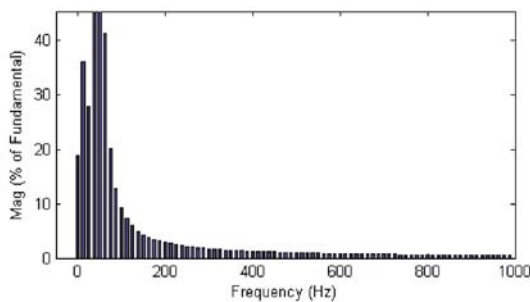

Fig. 7e: Frequency spectrum of input current

VSI fed BLDC motor with double boost converter

Fig 8a. shows the input voltage and input current waveform of Double Boost converter fed 3-phase inverter BLDC motor. It is seen that phase difference between input voltage and input current is highly reduced. The power factor is highly improved and it is nearer to unity. Fig 8b. shows the rotor speed of Double Boost converter fed 3-phase inverter BLDC motor. Fig 8c. shows the output current waveform. Fig 8d. shows the Frequency Spectrum of Double Boost converter fed 3-phase inverter BLDC motor where the

total harmonic distortion is 6.80%. It is observed that harmonics are reduced to 6.8% by using Double Boost converter fed 3-phase inverter.

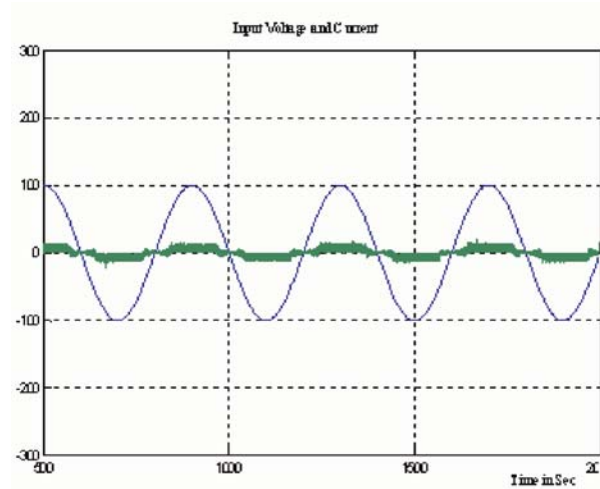

Fig. 8a: Input voltage and current wave forms

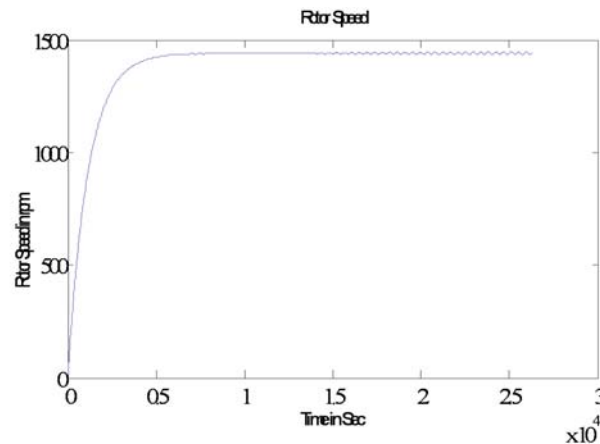

Fig. 8b: Rotor speed characteristic

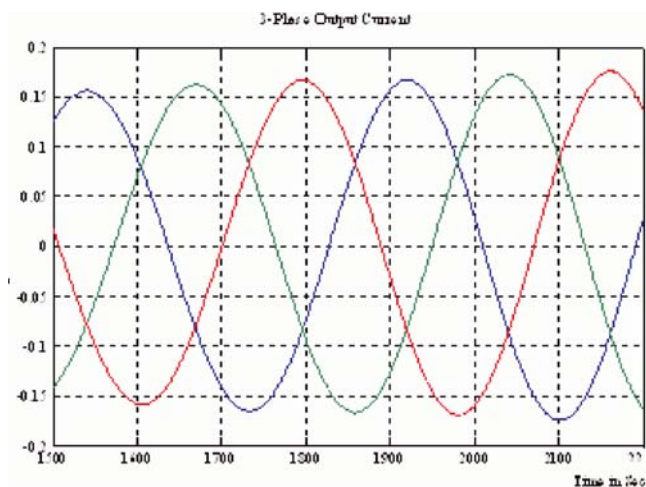

Fig. 8c: Stator current waveform

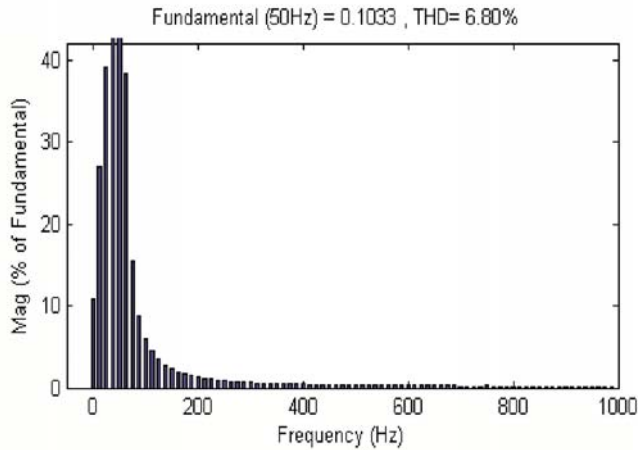

Fig. 8d: Frequency spectrum of input current

Table III.I: Comparison of THD in Phase Current

Types of converter	THD in phase current %
VSI fed PMSBLDC motor	20.28
VSI fed PMSBLDC motor with input L-filter	12.39
VSI fed PMSBLDC motor with input T-filter	11.59
VSI fed PMSBLDC motor with Double Boost Converter	6.80

Table III.II: Comparison of phase difference between Input voltage and input current

Types of converter	Phase difference between input voltage and input current
VSI fed PMSBLDC motor	90°
VSI fed PMSBLDC motor with input L-filter	72°
VSI fed PMSBLDC motor with input T-filter	54°
VSI fed PMSBLDC motor with double boost converter	0°

From the Table III.I, it can be seen that total harmonic distortion in phase currents are lesser in Double Boost Converter. From Table III.II, it can be seen the phase difference between input voltage and input current is 0°. This system has high power factor with less total harmonic distortion.

Conclusion

PMSBLDC drive system is modeled using the blocks of Simulink and the simulation results are presented. From the FFT analysis, it is observed that the THD is reduced by 7.89% by using series inductor filter. THD is reduced by 8.69% with T filter and it is reduced by 13.48% by using double boost converter. Thus the boost converter fed

PMSBLDC drive gives better performance since the heating due to harmonics is reduced.

The PWM inverter fed BLDC motor with power factor correction converter has been successfully simulated. The frequency spectrum for the output voltage was obtained. It is observed that the harmonics are minimum in the case of double boost converter fed 3- phase inverter system. From the simulation results of power factor correction converter, it is observed that double boost power factor correction converter is a better converter since the input power factor is nearly unity. This system has advantages like high power factor, low THD and reduced maintenance.

References

Alfio C. and Antonio T. (2004). Single chip Integration for Motor Drive Converters with Power factor Capability," *IEEE Trans. Power Electronics.*, **19**(6): 1372-1379.

Buso. S. (1998). Simple digital control improving dynamic performance of power factor pre-regulators, *IEEE Trans. Power Electron* **13**(5): 814-823.

Fu.Mand Chen.Q. (2001). A DSP based controller for power factor correction in a rectifier circuit, in Proc. *IEEE-APEC Annu. Meeting, Anaheim, CA, Mar. 4-8*, pp. 144-149.

Hao. L. and Toliyat H. A. (2003). BLDC motor full-speed operation using hybrid sliding mode observer, in Proc. *IEEE-APEC Annu. Meeting, Miami, FL, Feb. 9-13*, **1**: 286-293.

Krishnan.R (2002). Electric motor drives- modeling, analysis and control, Prentice Hall of India Private Limited.

Miller T. J. E. (1989). Brushless Permanent-Magnet and Reluctance Motor Drives, Oxford.

Pillay. P and Krishnan.R (1991). Application characteristics of permanent magnet synchronous and brushless dc motors for servo drives, *IEEE Trans.on Ind. Appl.*,**27**(5): 986--996.

Salih Baris Ozturk , Oh Yang, Hamid A. Toliyat (2007). Power Factor Correction of Direct Torque Controlled Brushless DC Motor Drive," *IEEE Conference*, pp 297-304.

Uzuka.K and Uzuhashi.H. (1985).Microcomputer Control for Sensorless Brushless Motor, *IEEE Trans. on Industry Application* ,.IA-21.

Zhou. J. (2001). Novel sampling algorithm for DSP controlled 2 kW PFC converter, *IEEE Trans. Power Electron.*, **16**(2): 217-222.

Received :April 01, 2009;

Accepted : February 17, 2011