

Simulation and Experimentation of Sawtooth Wave Generation using Diode-Capacitor Pair

A. Mallick, P. Guin, A. Roy*

Department of Electronics, West Bengal State University, Barasat, Kolkata, India 700126

Received 16 May 2021, accepted in final revised form 12 October 2021

Abstract

A simple, inexpensive and efficient circuit for generating sawtooth waves is demonstrated in this paper. The novelty of this work lies in the fact that the voltage of a charging capacitor provides linear response when it is charged through a reverse-biased diode. A rectangular wave of extremely high duty cycle is used as a reference signal to drive the passive circuit consists of a diode-capacitor pair. During the on-time of the reference signal, the diode remains in reverse biased condition while charging the capacitor and during charging through the reverse-biased diode, the capacitor voltage produces the required ramp. During the off-time of the reference wave, the diode becomes forward biased and the capacitor discharges very fast through the forward-biased diode and thus a sawtooth wave has resulted. At high frequencies, the parasitic depletion capacitance of the diode cannot be ignored and it limits the frequency of operation. Laboratory experiments, as well as PSPICE circuit simulations, are performed to established our idea of generating sawtooth waveforms. The experiment is found to be repetitive and robust.

Keywords: Constant current; Diode-capacitor circuit; Electronic waveform; Sawtooth.

© 2022 JSR Publications. ISSN: 2070-0237 (Print); 2070-0245 (Online). All rights reserved.

doi: <http://dx.doi.org/10.3329/jsr.v14i1.53478>

J. Sci. Res. **14** (1), 91-99 (2022)

1. Introduction

Circuits consisting of resistor, capacitor, inductor, diode, transistor along with the integrated circuit are taught at the undergraduate level of physics or electronics courses [1-3]. Multivibrator, wave-shaping, wave generation and wave conversion circuits are also common in the course curriculum of physics and electronics. In these circuits, usually timer IC555 and general-purpose operational amplifier IC741 are used in the laboratory course. Among the various wave generations circuits, sawtooth wave generation is a part of the laboratory course and this work presents the generation of the sawtooth wave using a simple and cost-effective method.

The application of the sawtooth wave is very wide. The area of its applications includes biomedical (especially, in neuroscience), communication, consumer electronics, switch-mode power supplies, scanning deflection of cathode ray tube beams, etc. Recently, the analysis of non-sinusoidal wave generation especially the generation of the

* Corresponding author: arjitroy@live.com

sawtooth wave is found to be of paramount importance in electric vehicle charging [4]. A sawtooth wave is commonly generated by using active devices such as transistors [1] and integrated circuits [5-8]. In most of these techniques, a rectangular or square wave is used as a reference frequency to obtain the desired frequency of the generated sawtooth wave. The basic principle of generating a sawtooth wave in these circuits is the same and is nothing but the generation of desired ramp voltage by charging a capacitor using a constant current source. Thus, modern circuits for generating sawtooth wave consists of mainly two parts. The first part generates the reference wave and the second part converts the reference wave into a sawtooth wave. The reference wave is used to control the frequency and amplitude of the generated sawtooth wave according to the requirement. It is to be noted here that the performance of a commonly used sawtooth wave generator by a pair of Op-Amp is better than our proposed circuit, however, our circuit is relevant when a high degree of accuracy is not desired at relatively low frequencies.

In this paper, an efficient method of generating sawtooth wave using diode–capacitor circuit is presented. The pair acts as a constant current source [9]. In our sawtooth wave generating circuit, a timer IC555-based rectangular wave generator is used as the reference frequency. Very good linearly is observed between the frequency of the input reference wave and the frequency of the generated sawtooth wave. The entire circuit is found to be efficient and cost-effective.

2. Circuit and Experiment

A complete cycle of a rectangular wave consists of two states namely High (on) and Low (off). For IC555, High and Low states mean, the oscillator output remains at 5 V and 0 V respectively. The time period of such rectangular wave is expressed as $T_R = T_H + T_L$, where T_H and T_L are the durations of time in the state of High and Low respectively in a cycle. In our present case, we need T_L to be infinitesimally small. The circuit for generating such a rectangular wave along with the generated wave form is shown in figure 1. A dual power supply ± 12 V is used to power up the circuits. The IC555 timer is powered up by $+12V-0$ and the Op-Amp is power up by ± 12 V.

In the circuit shown in Figure 1, the capacitor, C_A charges through the resistance R_A and discharges very fast since, the Pin 6 and 7 are shorted. Therefore, the time period of the rectangular wave generated by the IC555 (at Pin 3) is given by,

$$\begin{aligned} T_R &= T_H + T_L \\ &= R_A C_A \ln \left(\frac{\frac{2}{3}V_{CC}}{\frac{1}{3}V_{CC}} \right) + R_{67} C_A \ln \left(\frac{\frac{2}{3}V_{CC}}{\frac{1}{3}V_{CC}} \right) \\ &= R_A C_A \ln 2 + R_{67} C_A \ln 2 \end{aligned} \quad (1)$$

here, R_{67} represents the resistance (infinitesimally small) between the shorted Pins 6 and 7. Theoretically, the second term at the right-hand side of the above Eq is zero. Thus, the frequency of the reference wave is controlled by the pair R_A-C_A . Note the duty cycle of the rectangular wave is extremely high and this is because the Low time (T_L) is

infinitesimally small. Therefore, $TR \approx TH$ and duty cycle ($T_H \times 100/T_R$) approaches to 100 %.

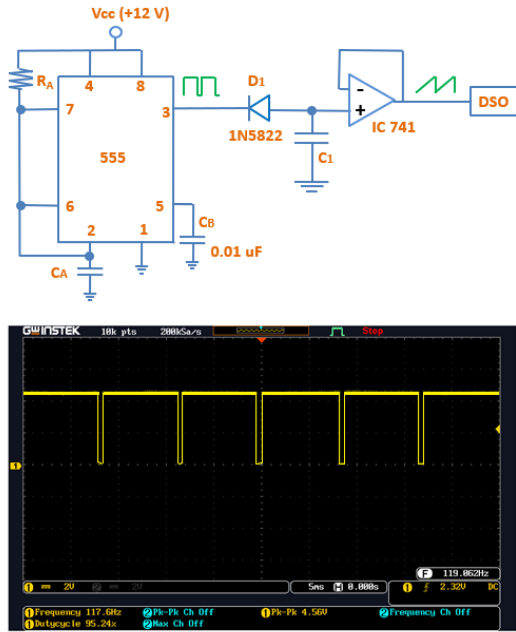

Fig. 1. (Top) The complete circuit of generating sawtooth wave. (Bottom) The reference waveform at Pin 3 of the IC555. The High time T_H is controlled by the pair R_A – C_A . The Pin 6 and 7 are shorted and allows C_A to discharge within an infinitesimally small period of time. $R_A = 2\text{ k}\Omega$ and $C_A = 6\text{ }\mu\text{F}$ is used to generate the above rectangular reference wave.

The reference wave drives the passive pair diode–capacitor (D_1 – C_1) and produces a sawtooth wave. During the High state of the reference wave, the capacitor, C_1 charges through the reversed-biased diode, D_1 and provides a linear ramp voltage as a function of time [9]. The rate of change of the charging voltage (V_{C_1}) of the capacitor C_1 is related to diode current using Shockley diode equation as follows..

$$I_d = I_s \left(e^{\frac{V_d}{\eta V_T}} - 1 \right) = C_1 \frac{dV_{C_1}}{dt} \tag{2}$$

where, I_d is the diode current, I_s is the reverse saturation current, V_d is the applied voltage across the diode, η is the ideality factor (lies between 1 and 2) and V_T is the thermal voltage (is about 26 mV at room temperature). In our present case the magnitude of the reference signal in the High state is 5 V and therefore, $V_d = -5\text{ V}$ (the negative sign appears due to the fact that the diode connected in reverse-biased condition) while charging the capacitor C_1 . The exponential term in Eq. (2) is extremely small and hence can be ignored in comparison to 1. Thus Eq. (2) becomes,

$$I_d = -I_s = C_1 \frac{dV_{C_1}}{dt} \tag{3}$$

The negative sign in Eq. (3) represents the direction of the current flow (since the current is flowing in the reverse direction of the diode). Using Eq. (3), the capacitor voltage is therefore expressed by (omitting the negative sign)

$$V_{C_1}(t) = \frac{I_s}{c_1} \int_0^t dt = \frac{I_s}{c_1} t \quad (4)$$

From Eq. (4), we can see that the diode D_1 supplies a constant current of magnitude I_s while charging the capacitor C_1 . Thus, the capacitor charging voltage V_{C_1} holds a linear relationship with time.

On the other hand, the discharging of the capacitor C_1 takes place very fast since, during the Low state, the diode D_1 remains in forward-biased condition and a forward-biased diode offers a little resistance to the current flow. The detail analysis of diode–capacitor circuit can be found in published papers [9-10]. Thus, as a consequence of repetitive charging and discharging of the capacitor C_1 , a sawtooth wave is generated. Next to the diode–capacitor pair, an optional buffer circuit (based on general purpose operational amplifier IC741) is used. The input impedance of the buffer circuit used here is extremely high and hence the loading effect at the capacitor voltage V_{C_1} is significantly reduced. Hence, discharging of the capacitance C_1 through the input impedance of the buffer circuit can be neglected.

3. Circuit Simulation

The selection of the diode (D_1 in Figure 1) is very important for the experiment. It is also important to know the reverse saturation current (I_s) of the diode to design the circuit, since I_s is the most important parameter that decides the slope of the ramp (see Eq. (4)). Instead of Si and Ge diodes, Schottky diode is considered for the diode, D_1 . The reverse saturation current in Schottky, as well as Ge diodes, is of the order of μA . Whereas the same in Si diode is of the order of nA . It is to be recalled here that the capacitor, C_1 should discharge very fast through the diode in the forward-biased condition [10]. This is possible when the forward voltage drop of the diode is small. In other words, the diode should offer negligible resistance in the forward-biased condition and the Schottky diode offers lower forward resistance than that of Ge diode [9]. Because of these reasons, the Schottky diode is chosen for this experiment.

In order to design the circuit, before the actual experiment, simulation is performed using PSPICE. First, using simulation, the reverse saturation current is of the selected diode is estimated. In estimating the reverse saturation current, the most conventional technique is applied as described below.

By taking logarithm at both sides of the Eq. (2), one obtains

$$\ln I_d = \frac{V_d}{\eta V_T} - \ln I_s \quad (5)$$

The above Equation holds good near the cut-off voltage of the diode. Eq. (5) can be expressed as

$$y = mx + c \quad (6)$$

where, $y = \ln I_d$, $c = \ln I_s$ and, $m = \frac{1}{\eta V_T}$ is the slope of the straight line expressed by the Eq (6). The simulated result is shown in Fig. 2.

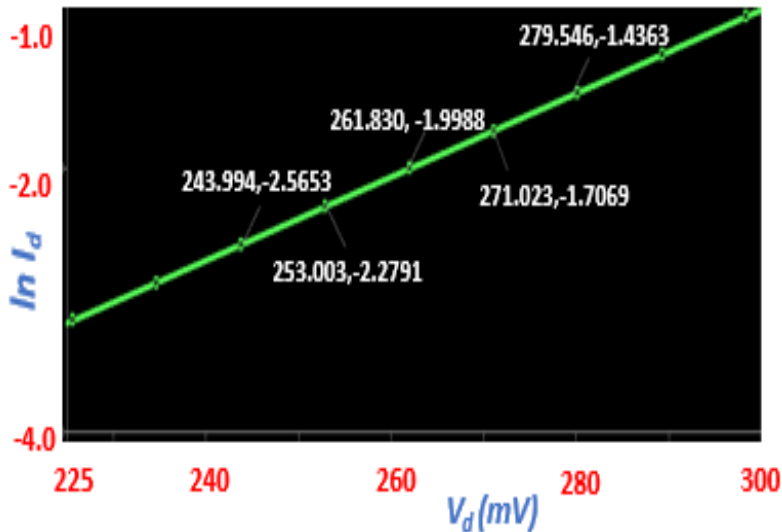

Fig. 2. Simulated Plot of $\ln I_d$ versus V_d for the purpose of measurement of reverse saturation current of the diode.

After knowing the reverse saturation current, the value of the charging-discharging capacitor (C_1) is to be estimated using Eq (4) for the desired ramp. Next, the pair R_A – C_A is to be chosen in such a way so that the desired time period (TT) of the sawtooth wave is nearly equal to the time period TR expressed by the Eq. (1) ignoring its second term at the righthand side.

It is to be noted here that the reverse saturation current may vary to some extent depending on the brand, the batch of production and operating temperature, etc. of the diode D_1 . Therefore, the reverse saturation current cannot be left as a floating design parameter and is required to be estimated as described above to minimize the effect of its variation. After estimating the components, the entire circuit shown in Fig. 1 is simulated.

4. Results and Discussion

Using the circuit shown in Figure 1 with different combinations of R_A and C_A , sawtooth waves of various frequencies are generated through simulations and as well as experiments. As a representative, five cases are shown in this work and these five cases are tabulated in Table 1. The generated sawtooth waveforms of these cases are shown in Figs. 3 and 4. Fig. 3 displays the sawtooth waveforms generated through the experimental method while Fig. 4 shows the same which are obtained through simulations. In our practical circuits, the tolerances of resistances and capacitors are 10 % and 20 % respectively. More precision components would yield better experimental results.

Table 1. Various cases of sawtooth wave generation.

Cases	Method	Frequency (Hz)	RA (k Ω)	CA (μ F)	C1 (nF)
Case 1	Experient	2.2	1	660	320
Case 2	Experient	112.7	2	6	5.2
Case 3	Simulation	10	1	144	640
Case 4	Simulation	100	1	14.4	64
Case 5	Simulation	1000	1	1.44	6.4

When a pair of Op-Amp is used to generate the sawtooth wave [8], a little flat portion is observed in the generated waveform. Though this flat portion is small in length and it is commonly found when the signal crosses the zero-voltage line during every ramp. Such kind of non-linearity is not observed in the output waveform generated by our method. In addition to this, in our case, the voltage of the output waveforms varies from 0 to 5 V (Figs. 3 and 4). On the other hand, when the sawtooth wave is generated by other means contains a negative cycle too. Hence, our circuit can be directly integrated with digital circuits or systems, since digital circuits operate or function in the voltage range of 0 to 5 V and thus advantageous.

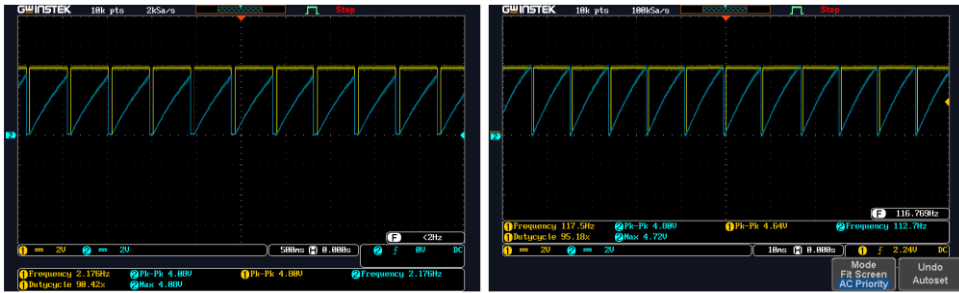

Fig. 3. Generated sawtooth waveforms through experiments. (Left) Case-1: $R_A = 1$ k Ω , $C_A = 660$ μ F, $C_1 = 320$ nF. (Right) Case-2: $R_A = 2$ k Ω , $C_A = 6$ μ F, $C_1 = 5.2$ nF.

In Fig. 3, a small difference in amplitudes between the reference wave and generated sawtooth wave can be noticed. This difference is due to the non-availability of the capacitor C_1 as per theoretical calculation and in the experimentation, we have taken the closest available value of C_1 . In the case of the simulation this error is eliminated (Fig. 4) and this is because of the exact value of the component is chosen. A little non-linearity in the ramp is also noticed. This non-linearity arises mainly due to the dependence of reverse saturation current on the applied reverse voltage. A comparison among the various methods of generating sawtooth wave is presented in Table 2. It can be found that our circuit is advantageous in comparison other sawtooth wave generating circuits.

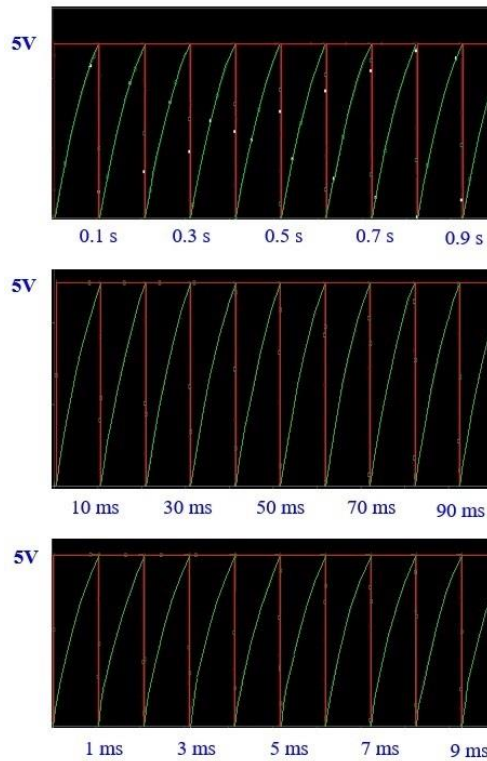

Fig. 4. Generated sawtooth wave forms using PSPICE simulation. (Top) Case-3: $R_A = 1 \text{ k}\Omega$, $C_A = 144 \text{ }\mu\text{F}$, $C_1 = 640 \text{ nF}$. (Middle) Case-4: $R_A = 1 \text{ k}\Omega$, $C_A = 14.4 \text{ }\mu\text{F}$, $C_1 = 64 \text{ nF}$. (Bottom) Case-5: $R_A = 1 \text{ k}\Omega$, $C_A = 1.44 \text{ }\mu\text{F}$, $C_1 = 6.4 \text{ nF}$.

It is interesting to note that in practice at higher frequencies, the parasitic depletion capacitance in the reverse-biased condition cannot be ignored anymore and limits the high-frequency operation. The width of the depletion region increases as the reverse bias voltage increases, and hence, the depletion capacitance decreases. According to the data sheets, the typical value of depletion capacitance (in the range of -1 V to -5 V , sometimes the depletion capacitance is termed as 'junction capacitance' in datasheets) in Si, Ge, and Schottky diodes are roughly 15 pF , 1 pF and 350 pF respectively. Eq. (4) tells us that higher frequency operation requires lower capacitance (C_1). The parasitic depletion capacitance cannot be ignored when the depletion capacitance becomes comparable to the external capacitor (C_1) and hence limits the highest possible frequency of the generated sawtooth wave.

Among the Si, Ge, and Schottky diodes, the depletion capacitance is highest for the Schottky diode and is lowest for the Ge diode. Hence, one may speculate that the Ge diode should be considered for high frequency operation. However, reverse saturation current is highest for the Schottky diode among the three diodes and thus charges the capacitor, C_1 faster. Hence, a trade-off is to be made between the reverse saturation current

and the depletion capacitance in selecting the diode D_1 , especially for high-frequency operation. This trade-off parameter can be defined as $S = I_s/C_d$ (in V/s) and the higher the value of S, the better is the diode for high-frequency operation. Assuming I_s to be 1 nA, 1 μ A and 2 μ A for Si, Ge and Schottky diodes respectively, the estimated values of S are 66.66 V/s, 10^6 V/s and 5.71×10^3 V/s respectively. Hence, the Ge diode should provide the highest frequency of operation. Though the S value of the Ge diode is much higher than that of the Schottky diode, a little benefit is experimentally observed for the Ge diode as far as high-frequency operation is concerned.

Another important design parameter is the forward resistance of the diode D_1 . The smaller the forward resistance of the diode D_1 , the faster is the discharge time of the capacitor C_1 and yields better shape of the sawtooth wave. Since forward resistance is smallest for the Schottky diode among the Si, Ge, and Schottky diodes, very sharp discharge is obtained. This is one of reason of choosing the Schottky diode for the experiment. In fact, with the Schottky diode, sharper transition than other methods (of generating sawtooth wave) is obtained. Due to the smaller forward resistance, the Schottky diode is preferred, since other diodes like the Ge and Si are not able to provide sharp discharging responses even at low frequencies.

Table 2. Comparison among the various methods of sawtooth wave generation.

References	About the circuit	Remarks
Ref 5	One IC555, few active devices and passive components are used.	1. Our circuit consumes least power.
Ref 6	Pair of Op-Amp and passive components are used.	2. Our circuit is simplest and cost effective.
Ref 7	Large number of ICs and passive components are used.	3. Our circuit produces highly linear output with respect to the frequency of the input reference signal.
Ref 8	Pair of Op-Amp and passive components are used.	4. Output of our Circuit ranges from 0 to 5 V. Hence our circuit can be directly integrated with the digital circuits and systems.
Our work	One IC 555 and few Passive components are used.	

5. Conclusion

An efficient and simple circuit is presented for the purpose of sawtooth wave generation. One of the unique features of our circuit is that it is constructed using components that are easily available in the laboratory. The theory of operation of the circuit is described in detail. The operation is verified through experiments and simulations. The circuit is repetitive and robust enough and the experiment can easily be conducted in the undergraduate laboratory of physics. The heart of the circuit is a passive diode–capacitor pair that acts as a constant current source. Since, passive components are used the power consumption by our circuit would be lesser.

Acknowledgments

A. Mallick (IF170260) and P. Guin (IF150060) would like to thank Department of Science and Technology, Govt. of India for providing research fellowship under 'DST Inspire Fellow' scheme.

References

1. J. Millman, H. Taub and S. R. Mothiki, Pulse, Digital and Switching Waveforms, 3rd Edition (McGraw Hill Education, India, 2016) pp. 445–460.
2. T. J. Kelly, Eur. J. Phys. **36**, ID 055041(2015). <https://doi.org/10.1088/0143-0807/36/5/055041>
3. T.K. Paul, S. Roy, and R. R. Pal, J. Sci. Res. **13**, 85 (2021). <https://doi.org/10.3329/jsr.v13i1.47766>
4. L. Durante, Int. J. Process Syst. Eng. **4**,138 (2017). <https://doi.org/10.1504/IJPSE.2017.084751>
5. M. T. Abullamatti and M. K. Alabsi, Active Passive Electronic Components **27**, ID 702648 (2004). <https://doi.org/10.1080/08827510310001616867>
6. R. A. Gayakwad, Op-amps and Linear Integrated Circuits, 4th Edition (PHI Learning Private Limited, 2013) pp. 294–298.
7. J. Jerabek, R. Sotner, N. Herencsar, J. Dvorak, and K. Vrba, Electronically Controllable Square/Triangular Wave Generator with Current-Controlled Differential Difference Current Conveyors - *41st Int. Conf. on Telecommunications and Signal Processing* (2018) pp. 1-6. <https://doi.org/10.1109/TSP.2018.8441499>
8. <https://www.falstad.com/circuit/e-sawtooth.html>, 15-10-2020, Sawtooth Wave Generator
9. A. Roy, A. Mallick, A. Adhikari, P. Guin, and D. Chatterjee, Am. J. Phys. **86**, 417 (2018). <http://doi.org/10.1119/1.5026994>
10. E. H. Hellen, Am. J. Phys. **71**, 797 (2003). <https://doi.org/10.1119/1.1578070>